



www.guangu.com



GUANGLU

GL/Y3

SERIES MOTOR

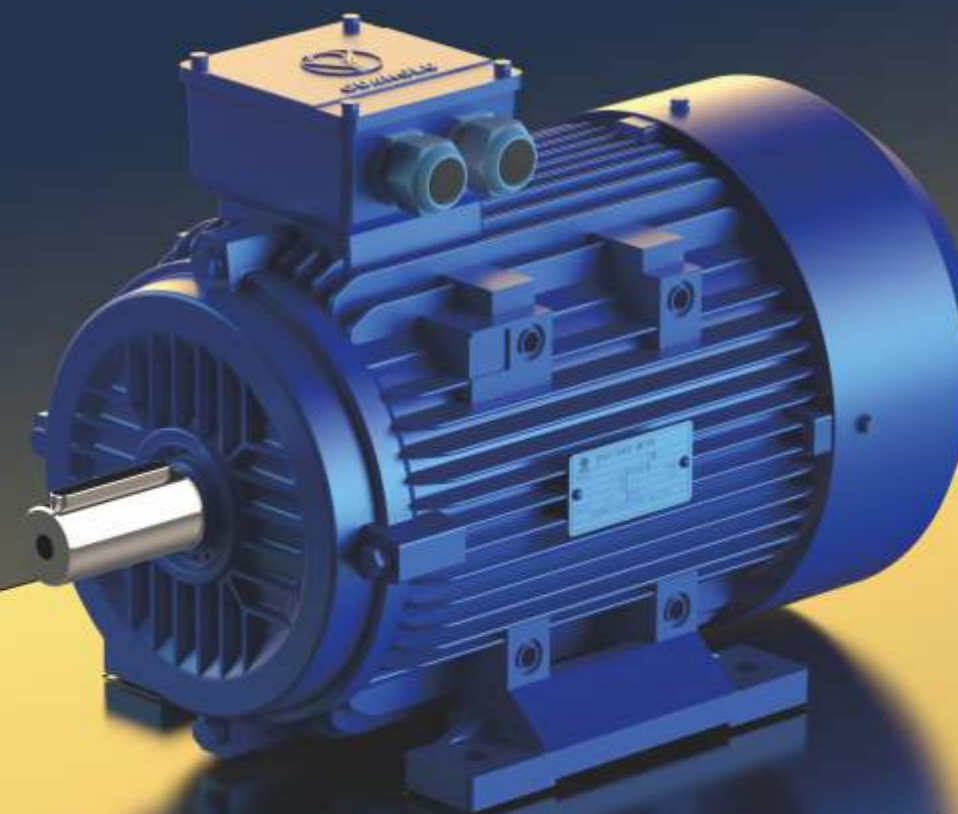

SHANGHAI GUANGLU MOTOR CO.,LTD.

Add: NO.388 Xinyu Rd,Songjiang , Shanghai, China.
Tel: 86-21-57735599 57735886
Fax: 86-21-57735500
E-mail: guangu@guangu.com

CHINA-GUANGLU ELECTRICAL CO.,LTD.

Add: Shanshi Ind.Zone,Wenling,Zhejiang pr.China
Tel: 86-576-86389888
Fax: 86-576-86388181
Export:86-576-86381188 86383600
E-mail: guangu@guangu.com

The information provided in this catalogue contains description or characteristics of performance which is case of actual use do not always apply as described or which may change as a result of further development of the products. An obligation to provide the respective characteristics shall only exist if expressly agreed in the terms of contract. Availability and technical specifications are subject to change without notice.



GUANGLU



GUANGLU, step by step in the highest flight



BRIEF INTRODUCTION

Located in ShanShi Industrial park of Taizhou City, — border on the picturesque scenery East China Sea, China · GuangLu Electrical Co., Ltd. Enjoys convenient transportation by water, land and air. The company occupies 25 thousand square meters and owns advanced producing equipments, it is a company specialized in electrical machinery manufacturing with all kinds of classifications, it is a member of Small and Medium-Sized Enterprises Electrical motor factory in the whole nation, it is a cooperated company with ShangHai Testing & Inspection Institute .

Our company was established in 80's, it was listed in the important industry member of key enterprise factory in WenLing, it is in the front of fifth strongest factory in DaXi. Furthermore, the company own excellent staff and a powerful scientific and technical system, advanced mode of production, hi-efficiency production facilities, continually renew testing equipments and consummate modernized management system. All products are according to the International IEC standard, it has arrived to the advanced level in the international same area. It has passed ISO9001:2000 International Quality Conformity, and got CCC 、CECP、CE Certificate, it is one of the biggest exported company in the Small and Medium Size in the Electrical area. In 2009,it was award "National Hi-Tech enterprise", YX3 series -high efficiency electrical motor has listed in the Energy Conservation Project.

Guanglu company specially produce IE2 series,Gost standard motor ,YX3 high efficiency motor, GM removeable single phase aluminium body motor,Y3,YZR3 series ,brake motor, double speed motor, vibrator motor, single phase series, Vibrators, high frequency vibrator stick, cutter, grinder ,etc. Guanglu products were saled to all over the world ,such as Europea, Middle east and our neighbors, the products are welcomed by customers and with favorable comments. In order to manufacture high quality products, Guanglu company introduced high efficiency production lines and increased new machining centers, such as lathe, automatic high speed stamping system, microcomputer test center, Coordinate Measurement System, control strictly from material select, machining ,manufacture, assembly to test, make the control system computerized and automated.

Guanglu make Science and technology as foremost, people oriented , improve quality constantly, most of products are superfine and high quality, are saled with good reputation in domestic and overseas market.

Guanglu company pursuing improvement spirit, advancing innovate independently, speed up the adjustment for products' structure, develop high-tech products energetically, perfect the technology, operate in high efficiency, with positive attitude as enterprise's belief, and serve customers with satisfied and excellence products and loyal service as the company tenet.



To manufacture high quality products, GUANGLU introduced numbers of equipments, as machining center, microcomputer test center, ect. From material select, machining, manufacture, assembly to test, every procedure is strictly controlled. The quality control is computerized and automated.

BEARING SIZE

Frame Size	Poles	Drive End	Non-Drive End
		International type	International type
56	2~4	62012RZ	62012RZ
63	2~4	62012RZ	62012RZ
71	2~6	62022RZ	62022RZ
80	2~8	62042RZ	62042RZ
90	2~8	62052RZ	62052RZ
100	2~8	62062RZ	62062RZ
112	2~8	63062RZ	63062RZ
132	2~8	63082RZ	63082RZ
160	2~8	63092ZC3	63092ZC3
180	2~8	6311C3	6311C3
200	2~8	6312C3	6312C3
225	2~8	6313C3	6313C3
250	2~8	6314C3	6314C3
280	2	6314C3	6314C3
	4~8	6317C3	6317C3
315	2	6317C3	6317C3
	4~10	NU319C3	6319C3
355	2	6319C3	6319C3
	4~10	NU322C3	6322C3
400	4~10	NU326C3	6326C3

MAIN DATA FOR TERMINAL BOX

Classified number	Frame size	Max.F.Amps	Entry hole size
			International standard
1	H56-80	2.6	2×M20×1.5
2	H90-100	6.8	2×M25×1.5
3	H112-132	15.4	2×M32×1.5
4	H160-180	42.5	2×M40×1.5
5	H200-225	84.2	2×M50×1.5
6	H250-280	166.6	2×M63×1.5
7	H315	358	2×M63×1.5
8	H355	546	2×M63×1.5
9	H400	600	3×M63×1.5

The mounting arrangements of the motors comply with IEC34-7 Recommendation. There are four basic arrangements shown as the following tables and figures.

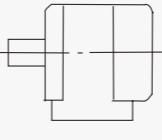
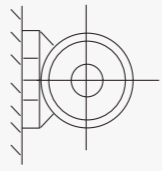
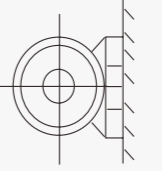
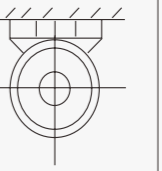
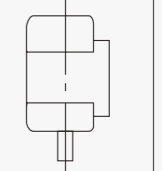
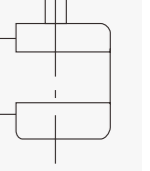
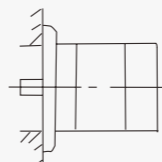
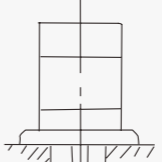
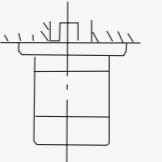
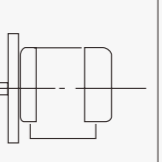
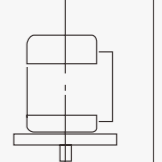
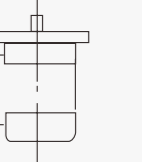
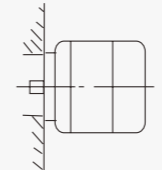
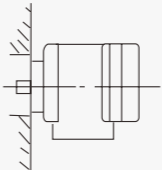
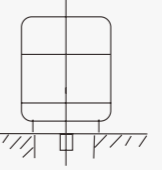
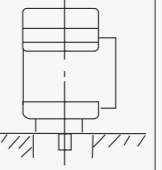
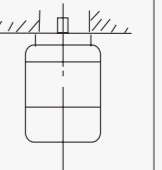
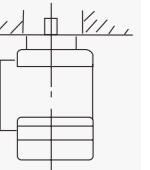
Fundamental arrangement	B3					
Mounting arrangement	B3	B6	B7	B8	V5	V6
Diagram						
Range of Manufacture (framesize)	56-400	56-355				
Fundamental arrangement	B5			B35		
Mounting arrangement	B5	V1	V3	B35	V15	V36
Diagram						
Range of Manufacture (framesize)	56-355	56-355	56-355	56-400	56-355	
Fundamental arrangement	B14					
Mounting arrangement	B14	B34	V18	V58	V19	V69
Diagram						
Range of Manufacture (framesize)	56-160					

GUANGLU MOTOR

LEADING TECHNOLOGY

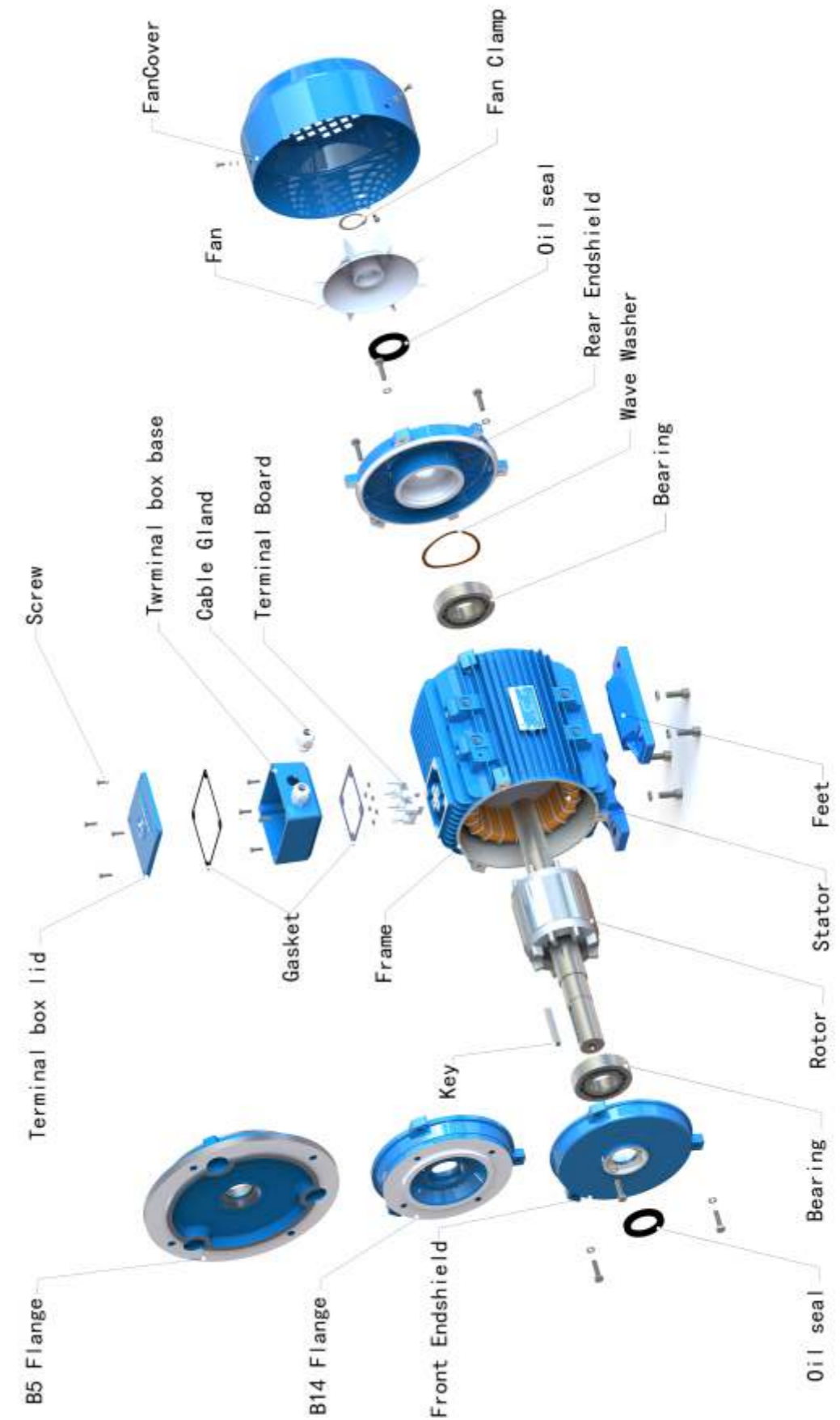
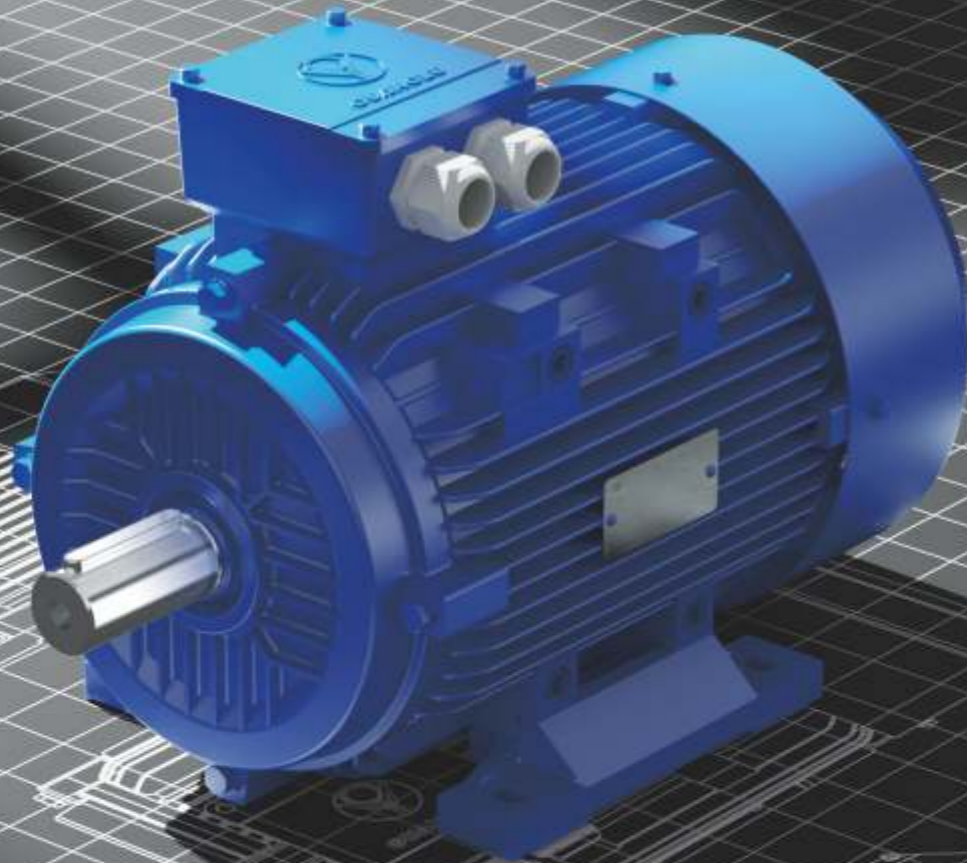



TECHNICAL DATA OF GL SERIES

NO.	Frame reference and size	Rated power		Full load current at rated voltage			Full load speed in revolutions per minute	Frequency at constant power	Direct on line starting torque ratio	Direct on line pull out torque ratio	Direct on line starting current ratio	Efficiency	Power factor	Rotor inertia WK ²								
		Power		Amps (A)											Speed	Frequency	LRT	BDT	LRA	η	Power factor (cosΦ)	J
		kW	HP	380V	400V	415V																
1	GL-561-2	0.09	0.12	0.29	0.27	0.26	2700	50	2.2	2.1	5.2	62.00	0.77	0.18								
2	GL-562-2	0.12	0.16	0.37	0.35	0.33	2700	50	2.2	2.1	5.2	64.00	0.78	0.23								
3	GL-63M1-2	0.18	0.25	0.53	0.5	0.49	2720	50	2.3	2.3	5.5	65.00	0.80	0.31								
4	GL-63M2-2	0.25	0.34	0.69	0.65	0.63	2720	50	2.3	2.3	5.5	68.00	0.81	0.6								
5	GL-71M1-2	0.37	0.5	1.01	0.96	0.92	2755	50	2.2	2.3	6.1	69.00	0.81	0.75								
6	GL-71M2-2	0.55	0.75	1.38	1.3	1.26	2790	50	2.3	2.3	6.1	74.00	0.82	0.9								
7	GL-80M1-2	0.8	1	1.77	1.67	1.6	2840	50	2.3	2.2	6.1	75.00	0.83	1.2								
8	GL-80M2-2	1.1	1.5	2.61	2.34	2.24	2840	50	2.3	2.2	6.9	76.20	0.84	1.4								
9	GL-90S-2	1.5	2	3.46	3.29	3.15	2850	50	2.3	2.2	7.0	78.50	0.84	2.9								
10	GL-90L-2	2.2	3	4.85	4.6	4.4	2855	50	2.3	2.2	7.0	81.00	0.85	5.5								
11	GL-100L-2	3	4	6.34	6.02	5.77	2860	50	2.3	2.2	7.5	82.60	0.87	10.9								
12	GL-112M-2	4	5.5	8.2	7.8	7.46	2880	50	2.3	2.2	7.5	84.20	0.88	12.6								
13	GL-132S1-2	5.5	7.5	11.1	10.5	10.1	2900	50	2.3	2.2	7.5	85.70	0.88	37.7								
14	GL-132S2-2	7.5	10	14.9	14.15	13.56	2900	50	2.3	2.2	7.5	87.00	0.88	49.9								
15	GL-160M1-2	11	15	21.3	20.2	19.4	2930	50	2.3	2.2	7.5	88.00	0.89	55								
16	GL-160M2-2	15	20	28.8	27.4	26.2	2930	50	2.3	2.2	7.5	89.00	0.89	75								
17	GL-160L-2	18.5	25	34.7	32.97	31.6	2930	50	2.3	2.2	7.5	90.00	0.90	124								
18	GL-561-4	0.06	0.08	0.23	0.22	0.21	1300	50	2.1	2.0	4.0	56.00	0.70	3								
19	GL-562-4	0.09	0.12	0.33	0.31	0.30	1300	50	2.1	2.0	4.0	58.00	0.72	4								
20	GL-63M1-4	0.12	0.16	0.44	0.42	0.40	1310	50	2.2	2.1	4.4	57.00	0.72	5								
21	GL-63M2-4	0.18	0.25	0.62	0.59	0.56	1310	50	2.2	2.1	4.4	60.00	0.73	6								
22	GL-71M1-4	0.25	0.34	0.79	0.75	0.72	1340	50	2.2	2.1	5.2	65.00	0.74	8								
23	GL-71M2-4	0.37	0.5	1.12	1.1	1.0	1340	50	2.2	2.1	5.2	67.00	0.75	1.3								
24	GL-80M1-4	0.55	0.75	1.52	1.44	1.38	1390	50	2.3	2.4	5.2	71.00	0.75	1.8								
25	GL-80M2-4	0.8	1	1.95	1.85	1.77	1390	50	2.3	2.3	6.0	73.00	0.76	2.1								
26	GL-90S-4	1.1	1.5	2.85	2.7	2.6	1390	50	2.3	2.3	6.0	76.20	0.77	2.3								
27	GL-90L-4	1.5	2	3.72	3.53	3.39	1400	50	2.3	2.3	6.0	78.50	0.78	2.7								
28	GL-100L1-4	2.2	3	5.09	4.83	4.6	1420	50	2.3	2.3	7.0	81.00	0.81	5.4								
29	GL-100L2-4	3	4	6.78	6.4	6.17	1420	50	2.3	2.3	7.0	82.60	0.82	6.7								

TECHNICAL DATA OF GL SERIES

NO.	Frame reference and size	Rated power		Full load current at rated voltage			Full load speed in revolutions per minute	Frequency at constant power	Direct on line starting torque ratio	Direct on line pull out torque ratio	Direct on line starting current ratio	Efficiency	Power factor	Rotor inertia WK ²
		Power		Amps (A)										
		kW	HP	380V	400V	415V								
					r/min	(HZ)	RLT	RLT	RLA	(%)	(cosΦ)	kg·m ² ·10 ³		
30	GL-112M-4	4	5.5	8.8	8.36	8.0	1435	50	2.3	2.3	7.0	84.20	0.82	9.5
31	GL-132S-4	5.5	7.5	11.7	11.12	10.65	1440	50	2.3	2.3	7.0	85.70	0.83	21.4
32	GL-132M-4	7.5	10	15.6	14.8	14.2	1450	50	2.3	2.3	7.0	87.00	0.84	29.6
33	GL-160M-4	11	15	22.3	21.2	20.3	1460	50	2.3	2.3	7.0	88.00	0.85	74.7
34	GL-160L-4	15	20	30.1	28.6	27.4	1460	50	2.3	2.3	7.0	89.00	0.85	91.8
35	GL-71M1-6	0.18	0.25	0.74	0.7	0.67	870	50	2.0	1.9	4.0	56.00	0.66	1.1
36	GL-71M2-6	0.25	0.34	0.95	0.9	0.86	870	50	2.0	1.9	4.0	59.00	0.68	1.4
37	GL-80M1-6	0.37	0.5	1.23	1.17	1.12	880	50	2.0	1.9	4.7	62.00	0.70	1.6
38	GL-80M2-6	0.55	0.75	1.7	1.6	1.55	880	50	2.1	1.9	4.7	65.00	0.72	1.9
39	GL-90S-6	0.8	1	2.29	2.18	2.08	905	50	2.1	2.0	5.3	69.00	0.72	2.9
40	GL-90L-6	1.1	1.5	3.18	3.02	2.9	905	50	2.1	2.0	5.5	72.00	0.73	3.5
41	GL-100L-6	1.5	2	4.0	3.8	3.64	920	50	2.1	2.0	5.5	76.00	0.76	6.9
42	GL-112M-6	2.2	3	5.6	5.32	5.1	935	50	2.1	2.0	6.5	79.00	0.76	14
43	GL-132M1-6	3	4	7.4	7.03	6.73	960	50	2.1	2.1	6.5	81.00	0.76	28.6
44	GL-132S-6	4	5.5	9.5	9.03	8.65	960	50	2.1	2.1	6.5	82.00	0.76	35.7
45	GL-132M2-6	5.5	7.5	12.6	11.97	11.16	960	50	2.1	2.1	6.5	84.00	0.77	44.9
46	GL-160M-6	7.5	10	16.9	16.1	15.6	970	50	2.1	2.0	6.5	86.00	0.78	81
47	GL-160L-6	11	15	24.2	22.99	22.02	970	50	2.1	2.0	6.5	87.50	0.79	11.6
48	GL-80M1-8	0.18	0.25	0.85	0.84	0.80	645	50	1.9	1.8	3.3	51.00	0.61	2.5
49	GL-80M2-8	0.25	0.34	1.15	1.05	1.06	645	50	1.9	1.8	3.3	54.00	0.61	3
50	GL-90S-8	0.37	0.5	1.49	1.4	1.36	675	50	1.9	1.8	4.0	62.00	0.61	5.1
51	GL-90L-8	0.55	0.75	2.17	2.06	2.0	680	50	2.0	1.8	4.0	63.00	0.61	6.5
52	GL-100L1-8	0.8	1	2.43	2.3	2.2	680	50	2.0	1.8	4.0	70.00	0.67	9.5
53	GL-100L2-8	1.1	1.5	3.36	3.2	3.06	680	50	2.0	1.8	5.0	72.00	0.69	11
54	GL-112M-8	1.5	2	4.4	4.22	4.04	690	50	2.0	1.8	5.0	74.00	0.70	24.5
55	GL-132S-8	2.2	3	6.0	5.7	5.46	710	50	2.0	1.8	6.0	79.00	0.71	31.4
56	GL-132M-8	3	4	7.8	7.4	7.1	710	50	2.0	1.8	6.0	80.00	0.73	39.5
57	GL-160M1-8	4	5.5	10.3	9.78	9.37	720	50	2.0	1.9	6.0	81.00	0.73	75.3
58	GL-160M2-8	5.5	7.5	13.6	12.9	12.38	720	50	2.0	2.0	6.5	83.00	0.74	93.1

TECHNICAL DATA OF GL SERIES

NO.	Frame reference and size	Rated power		Full load current at rated voltage			Full load speed in revolutions per minute	Frequency at constant power	Direct on line starting torque ratio	Direct on line pull out torque ratio	Direct on line starting current ratio	Efficiency	Power factor	Rotor inertia WK ²
		Power		Amps (A)										
		kW	HP	380V	400V	415V								
					r/min	(HZ)	RLT	RLT	RLA	(%)	(cosΦ)	kg·m ² ·10 ³		
1	GL-100L1-10	0.25	0.34	1.33	1.26	1.22	530	50	1.2	1.7	3.2	55.0	0.52	5.7
2	GL-100L2-10	0.37	0.5	1.89	1.80	1.73	530	50	1.2	1.7	3.2	56.0	0.53	7.3
3	GL-112M1-10	0.55	0.72	2.50	2.37	2.29	540	50	1.2	1.7	3.4	62.0	0.54	10.1
4	GL-112M2-10	0.8	1	3.30	3.12	3.01	540	50	1.2	1.7	3.4	63.0	0.55	12.3
5	GL-132S-10	1.1	1.5	4.40	4.20	4.00	550	50	1.2	1.7	3.6	69.0	0.55	27.4
6	GL-132M-10	1.5	2.2	5.70	5.50	5.20	565	50	1.2	1.7	3.6	71.0	0.56	35.1
7	GL-160M1-10	2.2	3	7.7	7.3	7.1	575	50	1.3	1.8	4.0	76.0	0.57	44.2
8	GL-160M2-10	6	4	10.2	9.7	9.4	575	50	1.3	1.8	4.0	77.0	0.58	84.1
9	GL-100L1-12	0.25	0.27	1.55	1.47	1.42	420	50	1.1	1.7	2.8	50.0	0.49	7.4
10	GL-100L2-12	0.37	0.5	2.21	2.10	2.02	425	50	1.1	1.7	2.8	52.0	0.49	10.3
11	GL-112M1-12	0.55	0.75	3.01	2.84	2.74	435	50	1.1	1.7	3.2	57.0	0.49	12.6
12	GL-132S1-12	0.8	1	3.60	3.40	3.30	440	50	1.1	1.7	3.4	63.0	0.50	28
13	GL-132S2-12	1.1	1.5	5.10	4.90	4.70	450	50	1.1	1.7	3.4	65.0	0.50	35.9
14	GL-132M-12	1.5	2	6.70	6.3	6.10	460	50	1.1	1.7	3.5	68.0	0.50	45.2
15	GL-160M-12	2.2	3	9.0	8.5	8.2	465	50	1.1	1.8	4.0	74.0	0.50	86.1
16	GL-160L-12	3	4	12.2	11.6	11.2	470	50	1.1	1.8	4.0	74.5	0.50	106.5
17	GL-112M1-16	0.25	0.34	1.52	1.44	1.39	310	50	0.9	1.6	2.5	48.0	0.47	28.5
18	GL-112M1-16	0.37	0.5	2.34	2.22	2.14	315	50	0.9	1.6	2.5	48.5	0.47	36.6
19	GL-132M-16	0.55	0.75	3.2	3.0	2.9	330	50	0.9	1.6	2.7	54.0	0.48	46
20	GL-160M1-16	0.8	1	3.8	3.6	3.4	340	50	0.9	1.6	2.8	62.0	0.48	87.7
21	GL-160M2-16	1.1	1.5	5.4	5.1	4.9	345	50	0.9	1.6	2.8	64.0	0.48	108.4
22	GL-160L-16	1.5	2	7.1	6.7	6.5	345	50	0.9	1.6	2.8	66.0	0.48	146.7

MOUNTING AND OVERALL DIMENSIONS IM B3 GL56-160

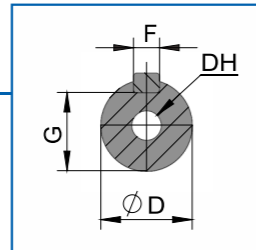
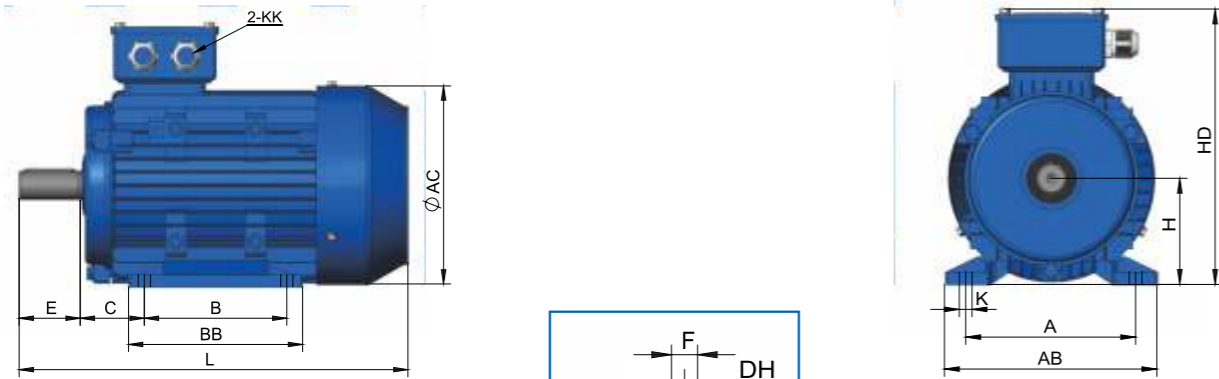

IM B5/IM B35 GL56-160

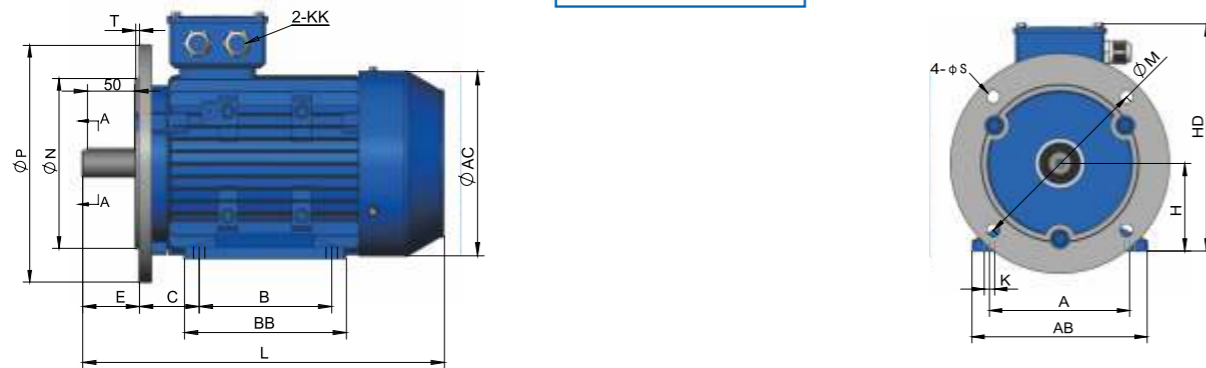

IM B14A GL56-160

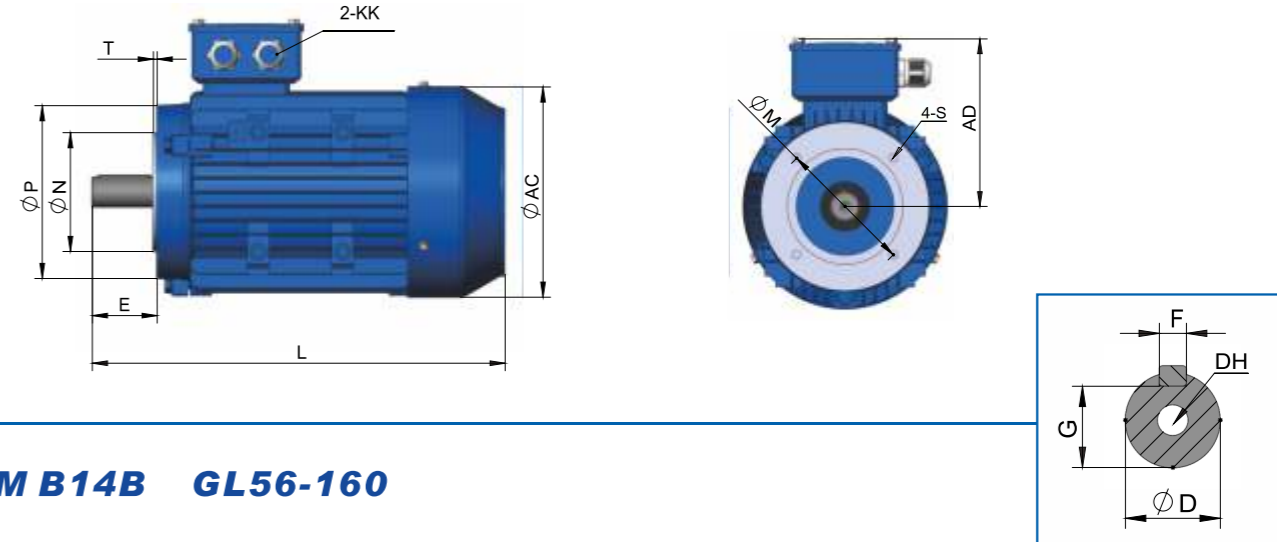

IM B14B GL56-160

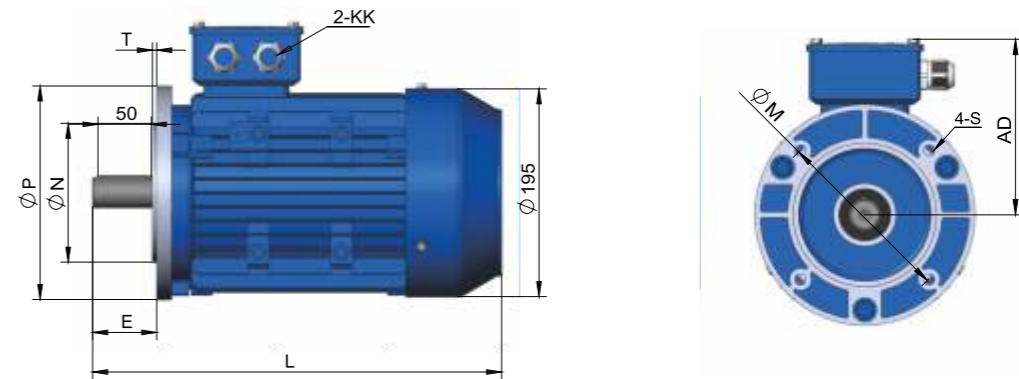

Frame size	Mounting dimensions															Overall dimensions									
	A	AA	AB	BB	HA	AC	AD	B	C	D	DH	E	F	G	H	K	KK		L	M	N	P	S	T	
METRIC	PG																								
GL56	90	23	115	88	7	110	100	71	36	9	M4×12	20	3	7.2	56	5.8	2-M20×1.5	2-PG13.5	199	100	80	120	Φ7	3.0	
GL63	100	24	137	100	7	123	111	80	40	11	M4×12	23	4	8.5	63	7.0	2-M20×1.5	2-PG13.5	221	115	95	140	Φ10	3.0	
GL71	112	26	138	110	8	137	127	90	45	14	M5×12	30	5	11	71	7.0	2-M20×1.5	2-PG13.5	247	130	110	160	Φ10	3.5	
GL80	125	35	141	125	9	155	136	100	50	19	M6×16	40	6	15.5	80	10.0	2-M20×1.5	2-PG13.5	290	165	130	200	Φ12	3.5	
GL90S	140	37	175	125	10	175	144	100	56	24	M8×19	50	8	20.0	90	10.0	2-M25×1.5	2-PG16	315	165	130	200	Φ12	3.5	
GL90L	140	37	175	150	10	175	144	125	56	24	M8×19	50	8	20.0	90	10.0	2-M25×1.5	2-PG16	340	165	130	200	Φ12	3.5	
GL100L	160	40	200	172	11	195	160	140	63	28	M10×22	60	8	24.0	100	12.0	2-M32×1.5	2-PG21	382	215	180	250	Φ15	4.0	
GL112M	190	41	226	181	12	220	183	140	70	28	M10×22	60	8	24.0	112	12.0	2-M32×1.5	2-PG21	400	215	180	250	Φ15	4.0	
GL132S	216	51	260	186	14.5	258	198	140	89	38	M12×28	80	10	33.0	132	12.0	2-M32×1.5	2-PG21	469	265	230	300	Φ15	4.0	
GL132M	216	51	260	224	14.5	258	198	178	89	38	M12×28	80	10	33.0	132	12.0	2-M32×1.5	2-PG21	508	265	230	300	Φ15	4.0	
GL160M	254	60	314	260	18	315	255	210	108	42	M16×36	110	12	37.0	160	15.0	2-M40×1.5	2-PG29	613	300	250	350	Φ19	5.0	
GL160L	254	60	314	304	18	315	255	254	108	42	M16×36	110	12	37.0	160	15.0	2-M40×1.5	2-PG29	658	300	250	350	Φ19	5.0	

Frame size	AC	AD	D	DH	E	F	G	KK		L	B14A					B14B				
								METRIC	PG		M	N	P	S	T	M	N	P	S	T
GL56	110	100	9	M4×12	20	3	7.2	2-M20×1.5	2-PG13.5	199	65	50	80	M5	2.5	85	70	105	M6	2.5
GL63	123	109	11	M4×12	23	4	8.5	2-M20×1.5	2-PG13.5	221	75	60	90	M5	2.5	100	80	120	M6	2.5
GL71	137	127	14	M5×12	30	5	11.0	2-M20×1.5	2-PG13.5	247	85	70	105	M6	2.5	115	95	140	M8	3.0
GL80	155	134	19	M6×16	40	6	15.5	2-M20×1.5	2-PG13.5	290	100	80	120	M6	3.0	130	110	160	M8	3.5
GL90S	175	140	24	M8×19	50	8	20.0	2-M25×1.5	2-PG16	315	115	95	140	M8	3.0	130	110	160	M8	3.5
GL90L	175	140	24	M8×19	50	8	20.0	2-M25×1.5	2-PG16	340	115	95	140	M8	3.0	130	110	160	M8	3.5
GL100L	195	160	28	M10×22	60	8	24.0	2-M32×1.5	2-PG21	382	130	110	160	M8	3.5	165	130	200	M10	3.5
GL112M	220	178	28	M10×22	60	8	24.0	2-M32×1.5	2-PG21	400	130	110	160	M8	3.5	165	130	200	M10	3.5
GL132S	258	206	38	M12×28	80	10	33.0	2-M32×1.5	2-PG21	469	165	130	200	M10	3.5	215	180	250	M12	4.0
GL132M	258	206	38	M12×28	80	10	33.0	2-M32×1.5	2-PG21	508	165	130	200	M10	3.5	215	180	250	M12	4.0
GL160M	315	255	42	M16×36	110	12	37.0	2-M40×1.5	2-PG29	613	215	180	250	M12	4.0	265	230	300	M16	5.0
GL160L	315	255	42	M16×36	110	12	37.0	2-M40×1.5	2-PG29	658	215	180	250	M12	4.0	265	230	300	M16	5.0

Y3

THREE-PHASE ASYNCHRONOUS MOTOR



Y3 THREE-PHASE ASYNCHRONOUS MOTOR

General introduction

Y3 series three-phase asynchronous motors, developed with new techniques.

Y3 series motors are defined as totally enclosed, fan cooled, squirrel cage type and noted for their novel design, beautiful model, compact structured, low noise, high efficiency, large torque, excellent starting performance, easy serving, etc. The motors are adopted with F class insulation and designed with assessing method for insulation system according to international practice, it enhances greatly have reached an international advanced level of the same kind of products at the initial days of the 90s.

Y3 series motors can be widely used as driving equipments of various machineries, such as machine tools, blowers, pumps, compressors, transporters, agricultural and food processing. Pedestal installation size and centre height and other indexes of the motor completely measured by Y3 series three-phase asynchronous motor.

Operating conditions

Ambient temperature: $-15^{\circ}\text{C} \sim 40^{\circ}\text{C}$ Altitude: Altitude should be higher than 1000 metres above sea level.
 Rated voltage: 380V, 400V, 415V, 440V. Rated frequency: 50Hz, 60Hz. Connection: Y Star-connection for 3kw or less whereas and delta-connection. Duty/Rating: Continuous (S1).
 Insulation class: F, the temperature rise of the stator winding is examined at 80K (by resistance method). Protection class: IP55.
 Cooling method: IC411.

TECHNICAL DATA OF Y3 SERIES **IE1**

NO.	Frame reference and size	Full load current at rated voltage			Rated power		Full load speed in revolutions per minute	Efficiency	Power factor	Direct on line starting torque ratio	Direct on line starting current ratio	Direct on line pull out torque ratio	Mean sound pressure level @1m on no load	Weight	Rotor inertia WK ²									
		Amps (A)			Power											Speed	EFF.	P.F.	LRT	LRA	BDT	Noise	Weight	Rotor inertia WK ²
		380V	400V	415V	kW	HP																		
1	Y3-80M1-2	1.77	1.74	1.68	0.8	1	2840	75.0	0.83	2.2	6.1	2.3	67	16	0.75									
2	Y3-80M2-2	2.61	2.48	2.39	1.1	1.5	2840	76.2	0.84	2.2	6.9	2.3	67	17	0.9									
3	Y3-90S-2	3.46	3.28	3.16	1.5	2	2850	78.5	0.84	2.2	7.0	2.3	72	20	1.2									
4	Y3-90L-2	4.85	4.61	4.45	2.2	3	2855	81.0	0.85	2.2	7.0	2.3	72	23	1.4									
5	Y3-100L-2	6.34	6.03	5.81	3	4	2860	82.6	0.87	2.2	7.5	2.3	76	30	2.9									
6	Y3-112M-2	8.2	7.79	7.51	4	5.5	2880	84.2	0.88	2.2	7.5	2.3	77	41	5.5									
7	Y3-132S1-2	11.1	10.53	10.15	5.5	7.5	2900	85.7	0.88	2.2	7.5	2.3	80	57.5	10.9									
8	Y3-132S2-2	14.9	14.1	13.6	7.5	10	2900	87.0	0.88	2.2	7.5	2.3	80	60.5	12.6									
9	Y3-160M1-2	21.2	20.2	19.5	11	15	2930	88.4	0.89	2.2	7.5	2.3	86	107	37.7									
10	Y3-160M2-2	28.6	27.2	26.2	15	20	2930	89.4	0.89	2.2	7.5	2.3	86	104	49.9									
11	Y3-160L-2	34.7	33.0	31.8	18.5	25	2930	90.0	0.90	2.2	7.5	2.3	86	133	55									
12	Y3-180M-2	41	39.0	37.6	22	30	2940	90.5	0.90	2.0	7.5	2.3	89	156	75									
13	Y3-200L1-2	55.4	52.6	50.7	30	40	2950	91.4	0.90	2.0	7.5	2.3	92	218	124									
14	Y3-200L2-2	67.9	64.5	62.2	38	50	2950	92.0	0.90	2.0	7.5	2.3	92	230	139									
15	Y3-225M-2	82.1	78.0	75.2	45	60	2960	92.5	0.90	2.0	7.5	2.3	92	290	233									
16	Y3-250M-2	100	94.8	91.4	55	75	2970	93.0	0.90	2.0	7.5	2.3	93	359	312									
17	Y3-280S-2	135	129	124	75	100	2975	93.6	0.90	2.0	7.0	2.3	94	494	579									
18	Y3-280M-2	160	152	147	90	125	2975	93.9	0.91	2.0	7.1	2.3	94	510	675									
19	Y3-315S-2	195	186	179	110	150	2975	94.0	0.91	1.8	7.1	2.2	96	875	1180									
20	Y3-315M-2	233	222	214	132	180	2975	94.5	0.91	1.8	7.1	2.2	96	963	1820									
21	Y3-315L1-2	279	265	256	160	220	2975	94.6	0.92	1.8	7.1	2.2	99	1010	2080									
22	Y3-315L2-2	348	331	319	200	270	2975	94.8	0.92	1.8	7.1	2.2	99	1138	2380									
23	Y3-355M-2	433	412	397	250	340	2980	95.2	0.92	1.6	7.1	2.2	103	1685	3000									
24	Y3-355L-2	545	518	499	315	430	2980	95.4	0.92	1.6	7.1	2.2	103	1855	3500									

TECHNICAL DATA OF Y3 SERIES **IE1**

NO.	Frame reference and size	Full load current at rated voltage			Rated power		Full load speed in revolutions per minute	Efficiency	Power factor	Direct on line starting torque ratio	Direct on line starting current ratio	Direct on line pull out torque ratio	Mean sound pressure level @1m on no load	Weight	Rotor inertia WK ²									
		Amps (A)			Power											Speed	EFF.	P.F.	LRT	LRA	BDT	Noise	Weight	Rotor inertia WK ²
		380V	400V	415V	kW	HP																		
1	Y3-80M1-4	1.57	1.49	1.44	0.55	0.75	1390	71	0.75	2.4	5.2	2.3	58	15	1.8									
2	Y3-80M2-4	2.05	1.95	1.88	0.8	1	1390	73	0.76	2.3	6.0	2.3	58	15.5	2.1									
3	Y3-90S-4	2.85	2.71	2.61	1.1	1.5	1390	76.2	0.77	2.3	6.0	2.3	61	19	2.3									
4	Y3-90L-4	3.72	3.54	3.41	1.5	2	1400	78.5	0.78	2.3	6.0	2.3	61	23	2.7									
5	Y3-100L1-4	5.09	4.90	4.72	2.2	3	1420	81	0.81	2.3	7.0	2.3	64	29	5.4									
6	Y3-100L2-4	6.78	6.39	6.16	3	4	1420	82.6	0.82	2.3	7.0	2.3	64	31	6.7									
7	Y3-112M-4	8.8	8.36	8.06	4	5.5	1435	84.2	0.82	2.3	7.0	2.3	65	42	9.5									
8	Y3-132S-4	11.7	11.2	10.8	5.5	7.5	1440	85.7	0.83	2.3	7.0	2.3	71	52	21.4									
9	Y3-132M-4	15.6	14.8	14.3	7.5	10	1450	87	0.84	2.3	7.0	2.3	71	64.5	29.6									
10	Y3-160M-4	22.5	21.4	20.6	11	15	1460	88.4	0.84	2.2	7.0	2.3	75	100	74.7									
11	Y3-160L-4	30	28.5	27.5	15	20	1460	89.4	0.85	2.2	7.5	2.3	75	129	91.8									
12	Y3-180M-4	36.3	34.5	33.3	18.5	25	1470	90	0.86	2.2	7.5	2.3	76	150	139									
13	Y3-180L-4	43.2	40.8	39.3	22	30	1470	90.5	0.86	2.2	7.5	2.3	76	166	158									
14	Y3-200L-4	57.6	55.1	53.1	30	40	1470	91.4	0.86	2.2	7.2	2.3	79	228	262.									
15	Y3-225S-4	70.2	66.7	64.3	38	50	1475	92	0.87	2.2	7.2	2.3	81	268	406									
16	Y3-225M-4	84.9	80.7	77.8	45	60	1475	92.5	0.87	2.2	7.2	2.3	81	313	469									
17	Y3-250M-4	103	98.1	94.6	55	75	1480	93	0.87	2.2	7.2	2.3	83	366	660									
18	Y3-280S-4	138.3	131	127	75	100	1480	93.6	0.88	2.2	6.8	2.3	86	480	1120									
19	Y3-280M-4	165	157	152	90	125	1480	93.9	0.88	2.2	6.8	2.3	86	560	1640									
20	Y3-315S-4	201	191	184	110	150	1480	94.5	0.88	2.1	6.9	2.2	93	846	3100									
21	Y3-315M-4	240	228	220	132	180	1480	94.8	0.88	2.1	6.9	2.2	93	940	3620									
22	Y3-315L1-4	288	273	264	160	220	1480	94.9	0.89	2.1	6.9	2.2	97	1044	4130									
23	Y3-315L2-4	360	342	329	200	270	1480	94.9	0.89	2.1	6.9	2.2	97	1162	4730									
24	Y3-355M-4	443	421	406	250	340	1490	95.2	0.90	2.1	6.9	2.2	101	1650	6500									
25	Y3-355L-4	559	531	511	315	430	1490	95.2	0.90	2.1	6.9	2.2	101	1810	8200									

TECHNICAL DATA OF Y3 SERIES IE1

NO.	Frame reference and size	Full load current at rated voltage			Rated power		Full load speed in revolutions per minute	Efficiency	Power factor	Direct on line starting torque ratio	Direct on line starting current ratio	Direct on line pull out torque ratio	Mean sound pressure level @1m on no load	Weight	Rotor inertia WK ²									
		Amps (A)			Power											Speed	EFF.	P.F.	LRT	LRA	BDT	Noise	Weight	J
		380V	400V	415V	kW	HP																		
1	Y3-80M1-6	1.3	1.23	1.19	0.37	0.5	880	62	0.70	1.9	4.7	2.0	54	15	1.6									
2	Y3-80M2-6	1.8	1.70	1.64	0.55	0.75	880	65	0.72	1.9	4.7	2.1	54	16	1.9									
3	Y3-90S-6	2.29	2.18	2.10	0.8	1	905	69	0.72	2.0	5.3	2.1	57	20	2.9									
4	Y3-90L-6	3.18	3.02	2.91	1.1	1.5	905	72	0.73	2.0	5.5	2.1	57	23	3.5									
5	Y3-100L-6	4	3.80	3.66	1.5	2	920	76	0.75	2.0	5.5	2.1	61	29	6.9									
6	Y3-112M-6	5.6	5.29	5.10	2.2	3	935	79	0.76	2.0	6.5	2.1	65	41	14									
7	Y3-132S-6	7.4	7.03	6.78	3	4	960	81	0.76	2.1	6.5	2.1	69	59	28.6									
8	Y3-132M1-6	9.75	9.26	8.93	4	5.5	960	82	0.76	2.1	6.5	2.1	69	66	35.7									
9	Y3-132M2-6	12.9	12.3	11.8	5.5	7.5	960	84	0.77	2.1	6.5	2.1	69	76.5	44.9									
10	Y3-160M-6	17.2	16.3	15.8	7.5	10	970	86	0.77	2.0	6.5	2.1	73	106	81									
11	Y3-160L-6	24.5	23.3	22.4	11	15	970	87.5	0.78	2.0	6.5	2.1	73	122	116									
12	Y3-180L-6	31.6	30.0	28.9	15	20	970	89	0.81	2.0	7.0	2.1	73	154	207									
13	Y3-200L1-6	38.6	36.6	35.3	18.5	25	980	90	0.81	2.1	7	2.1	76	202	315									
14	Y3-200L2-6	44.7	42.5	41.0	22	30	980	90	0.83	2.0	7	2.1	76	216	360									
15	Y3-225M-6	59.3	56.3	54.3	30	40	980	91.5	0.84	2.0	7	2.1	76	287	547									
16	Y3-250M-6	71	67.5	65.1	38	50	980	92	0.86	2.1	7	2.1	78	355	843									
17	Y3-280S-6	86	81.7	78.1	45	60	980	92.5	0.86	2.1	7	2	80	444	1390									
18	Y3-280M-6	104	99.5	95.9	55	75	980	92.8	0.86	2.1	7	2	80	498	1650									
19	Y3-315S-6	142	135	130	75	100	985	93.5	0.86	2.0	6.7	2	85	859	4110									
20	Y3-315M-6	169	161	155	90	125	985	93.8	0.86	2.0	6.7	2	85	950	4780									
21	Y3-315L1-6	207	196	189	110	150	985	94	0.86	2.0	6.7	2	85	1031	5450									
22	Y3-315L2-6	245	232	224	132	180	985	94.2	0.87	2.0	6.7	2	85	1107	6120									
23	Y3-355M1-6	292	278	268	160	220	990	94.5	0.88	1.9	6.7	2	92	1550	9500									
24	Y3-355M2-6	365	347	335	200	270	990	94.5	0.88	1.9	6.7	2	92	1645	10400									
25	Y3-355L-6	457	434	418	250	340	990	94.5	0.88	1.9	6.7	2	92	1854	12400									

TECHNICAL DATA OF Y3 SERIES IE1

NO.	Frame reference and size	Full load current at rated voltage			Rated power		Full load speed in revolutions per minute	Efficiency	Power factor	Direct on line starting torque ratio	Direct on line starting current ratio	Direct on line pull out torque ratio	Mean sound pressure level @1m on no load	Weight	Rotor inertia WK ²									
		Amps (A)			Power											Speed	EFF.	P.F.	LRT	LRA	BDT	Noise	Weight	J
		380V	400V	415V	kW	HP																		
1	Y3-80M1-8	0.88	0.84	0.80	0.18	0.25	645	51	0.61	1.8	3.3	1.9	52	15	2.5									
2	Y3-80M2-8	1.15	1.10	1.06	0.25	0.34	645	54	0.61	1.8	3.3	1.9	52	16	3.0									
3	Y3-90S-8	1.49	1.41	1.36	0.37	0.5	675	62	0.61	1.8	4	1.9	56	20	5.1									
4	Y3-90L-8	2.17	2.07	1.99	0.55	0.75	680	63	0.61	1.8	4	2	56	23	6.5									
5	Y3-100L1-8	2.43	2.31	2.22	0.8	1	680	70	0.67	1.8	4	2	59	29	9.0									
6	Y3-100L2-8	3.36	3.20	3.08	1.1	1.5	680	72	0.69	1.8	5	2	59	31	11.0									
7	Y3-112M-8	4.4	4.18	4.03	1.5	2	690	74	0.70	1.8	5	2	61	41	24.5									
8	Y3-132S-8	6.0	5.66	5.46	2.2	3	710	79	0.71	1.8	6	2	64	61	31.4									
9	Y3-132M-8	7.8	7.41	7.15	3	4	710	80	0.73	1.8	6	2	64	74	39.5									
10	Y3-160M1-8	10.3	9.76	9.41	4	5.5	720	81	0.73	1.9	6	2	68	95.5	75.3									
11	Y3-160M2-8	13.6	12.9	12.5	5.5	7.5	720	83	0.74	1.9	6	2	68	107	93.1									
12	Y3-160L-8	17.8	16.9	16.3	7.5	10	720	85.5	0.75	1.9	6	2	68	128	126									
13	Y3-180L-8	25.5	24.2	23.3	11	15	730	87.5	0.75	2	6.5	2	70	169	203									
14	Y3-200L-8	34.1	32.4	31.2	15	20	730	88	0.76	2	6.6	2	73	236	339									
15	Y3-225S-8	41.1	39.0	37.6	18.5	25	730	90	0.76	1.9	6.6	2	73	274	491									
16	Y3-225M-8	48.9	45.0	43.4	22	30	730	90.5	0.78	1.9	6.6	2	73	290	547									
17	Y3-250M-8	63	60.2	58.1	30	40	735	91	0.79	1.9	6.5	2	75	370	834									
18	Y3-280S-8	78	73.9	71.2	38	50	740	91.5	0.79	1.9	6.6	2	76	488	1650									
19	Y3-280M-8	94	89.4	86.1	45	60	740	92	0.79	1.9	6.6	2	76	563	1930									
20	Y3-315S-8	111	106	102	55	75	735	92.8	0.81	1.8	6.6	2	82	748	4790									
21	Y3-315M-8	150	143	138	75	100	735	93.5	0.81	1.8	6.2	2	82	854	5580									
22	Y3-315L1-8	178	169	163	90	125	735	93.8	0.82	1.8	6.4	2	82	970	6370									
23	Y3-315L2-8	217	206	199	110	150	735	94	0.82	1.8	6.4	2	82	1075	7230									
24	Y3-355M1-8	261	248	239	132	180	740	93.7	0.82	1.8	6.4	2	90	1575	7900									
25	Y3-355M2-8	315	299	288	160	220	740	94.2	0.82	1.8	6.4	2	90	1658	10300									
26	Y3-355L-8	387	368	355	200	270	740	94.5	0.83	1.8	6.4	2	90	1834	12300									

TECHNICAL DATA OF Y3 SERIES **IE1**

NO.	Frame reference and size	Full load current at rated voltage			Rated power		Full load speed in revolutions per minute	Efficiency	Power factor	Direct on line starting torque ratio	Direct on line starting current ratio	Direct on line pull out torque ratio	Mean sound pressure level @1m on no load	Rotor inertia WK ²								
		Amps (A)			Power										Speed	EFF.	P.F.	LRT	LRA	BDT	Noise	J
		380V	400V	415V	kW	HP																
1	Y3-100L1-10	1.33	1.26	1.22	0.25	0.34	530	55.0	0.52	1.2	3.2	1.7	59	5.7								
2	Y3-100L2-10	1.89	1.80	1.73	0.37	0.5	530	56.0	0.53	1.2	3.2	1.7	59	7.3								
3	Y3-112M1-10	2.50	2.37	2.29	0.55	0.75	540	62.0	0.54	1.2	3.4	1.7	61	10.1								
4	Y3-112M2-10	3.30	3.12	3.01	0.8	1	540	63.0	0.55	1.2	3.4	1.7	61	12.3								
5	Y3-132S-10	4.40	4.20	4.00	1.1	1.5	550	69.0	0.55	1.2	3.6	1.7	64	27.4								
6	Y3-132M-10	5.70	5.50	5.20	1.5	2	565	71.0	0.56	1.2	3.6	1.7	64	35.1								
7	Y3-160M1-10	7.7	7.3	7.1	2.2	3	575	76.0	0.57	1.3	4.0	1.8	68	44.2								
8	Y3-160M2-10	10.2	9.7	9.4	3	4	575	77.0	0.58	1.3	4.0	1.8	68	84.2								
9	Y3-180M-10	12.2	11.5	11.1	4	5.5	580	82.0	0.61	1.3	4.0	1.8	70	104.1								
10	Y3-180L-10	16.2	15.4	14.9	5.5	7.5	580	83.0	0.62	1.3	4.0	1.8	70	140.9								
11	Y3-200L1-10	20.6	19.5	18.8	7.5	10	580	84.0	0.66	1.3	4.5	1.8	73	227								
12	Y3-200L2-10	30.0	28.5	27.5	11	15	580	84.5	0.66	1.3	4.5	1.8	73	379								
13	Y3-225M1-10	39.2	37.2	35.9	15	20	580	85.5	0.68	1.3	4.5	1.8	73	548.9								
14	Y3-250M2-10	48.1	45.7	44.1	18.5	25	580	86.0	0.68	1.3	4.5	1.8	73	611.5								
15	Y3-280S-10	49.9	47.4	45.7	22	30	585	90.5	0.74	1.5	5.2	2.0	76	932.4								
16	Y3-280M1-10	67.7	64.3	62.0	30	40	585	91.0	0.74	1.5	5.2	2.0	76	1844.7								
17	Y3-280M2-10	83.5	79.3	76.5	38	50	585	91.0	0.74	1.5	5.2	2.0	76	2157.7								
18	Y3-315S-10	100	95	91	45	60	590	91.5	0.75	1.5	6.2	2.0	82	5355.2								
19	Y3-315M-10	121	115	111	55	75	590	92.0	0.75	1.5	6.2	2.0	82	6238.4								
20	Y3-315L1-10	162	154	148	75	100	590	92.5	0.76	1.5	5.8	2.0	82	7121.7								
21	Y3-315L2-10	191	181	175	90	125	590	93.0	0.77	1.5	5.9	2.0	82	8083.1								
22	Y3-355M1-10	230	218	211	110	150	590	93.2	0.78	1.5	6.0	2.0	90	10176								
23	Y3-355M2-10	275	261	252	132	180	590	93.5	0.78	1.5	6.0	2.0	90	11515.4								
24	Y3-355L-10	334	317	305	160	220	590	93.5	0.78	1.5	6.0	2.0	90	13751.4								

TECHNICAL DATA OF Y3 SERIES **IE1**

NO.	Frame reference and size	Full load current at rated voltage			Rated power		Full load speed in revolutions per minute	Efficiency	Power factor	Direct on line starting torque ratio	Direct on line starting current ratio	Direct on line pull out torque ratio	Mean sound pressure level @1m on no load	Rotor inertia WK ²								
		Amps (A)			Power										Speed	EFF.	P.F.	LRT	LRA	BDT	Noise	J
		380V	400V	415V	kW	HP																
1	Y3-100L1-12	1.55	1.47	1.42	0.25	0.34	420	50.0	0.49	1.1	2.8	1.7	59	7.4								
2	Y3-100L2-12	2.21	2.10	2.02	0.37	0.5	425	52.0	0.49	1.1	2.8	1.7	59	10.3								
3	Y3-112M1-12	3.01	2.84	2.74	0.55	0.75	435	57.0	0.49	1.1	3.2	1.7	61	12.6								
4	Y3-132S1-12	3.60	3.40	3.30	0.8	1	440	63.0	0.50	1.1	3.4	1.7	61	28								
5	Y3-132S2-12	5.10	4.90	4.70	1.1	1.5	450	65.0	0.50	1.1	3.4	1.7	64	35.9								
6	Y3-132M-12	6.70	6.30	6.10	1.5	2	460	68.0	0.50	1.1	3.5	1.7	64	45.2								
7	Y3-160M-12	9.0	8.5	8.2	2.2	3	465	74.0	0.50	1.1	4.0	1.8	68	86.1								
8	Y3-160L-12	12.2	11.6	11.2	3	4	470	74.5	0.50	1.1	4.0	1.8	68	106.5								
9	Y3-180L1-12	14.1	13.4	12.9	4	5.5	470	78.0	0.55	1.2	4.0	1.8	70	144.1								
10	Y3-180L2-12	18.5	17.6	16.9	5.5	7.5	475	79.0	0.57	1.2	4.0	1.8	70	232.2								
11	Y3-200L1-12	24.2	23.0	22.2	7.5	10	475	81.0	0.58	1.2	4.5	1.8	73	387.7								
12	Y3-225M1-12	33.1	31.5	30.3	11	15	480	84.0	0.60	1.2	4.5	1.8	73	561.6								
13	Y3-225M2-12	44.7	42.4	40.9	15	20	480	85.0	0.60	1.2	4.5	1.8	73	625.6								
14	Y3-250M-12	53.0	50.3	48.5	18.5	25	480	85.5	0.62	1.2	4.5	1.8	73	953.9								
15	Y3-280S-12	60.0	57.0	55.0	22	30	485	87.0	0.64	1.2	4.5	1.8	76	1887.1								
16	Y3-280M-12	80.1	76.1	73.3	30	40	485	87.5	0.65	1.2	4.5	1.8	76	2207.4								
17	Y3-315S-12	93.2	88.5	85.3	38	50	485	90.0	0.67	1.2	4.5	1.5	76	5478.4								
18	Y3-315M-12	112.8	107.1	103.2	45	60	485	90.5	0.67	1.2	4.5	1.5	82	6381.9								
19	Y3-315L1-12	137.3	130.5	125.8	55	75	485	90.8	0.67	1.2	4.5	1.5	82	7285.5								
20	Y3-315L2-12	186.9	177.6	171.1	75	100	485	91.0	0.67	1.2	4.5	1.5	82	8269.1								
21	Y3-355M1-12	212.3	201.7	194.4	90	125	490	92.0	0.70	1.2	4.5	1.7	82	10410								
22	Y3-355M2-12	258.4	245.4	236.6	110	150	490	92.4	0.70	1.2	4.5	1.7	90	11780.3								
23	Y3-355L-12	309.4	293.9	283.3	132	180	490	92.6	0.70	1.2	4.5	1.7	90	14067.7								

TECHNICAL DATA OF Y3 SERIES IE1

NO.	Frame reference and size	Full load current at rated voltage			Rated power		Full load speed in revolutions per minute	Efficiency	Power factor	Direct on line starting torque ratio	Direct on line starting current ratio	Direct on line pull out torque ratio	Mean sound pressure level @1m on no load	Rotor inertia WK ²								
		Amps (A)			Power										Speed	EFF.	P.F.	LRT	LRA	BDT	Noise	J
		380V	400V	415V	kW	HP																
1	Y3-112M1-16	1.52	1.44	1.39	0.25	0.34	310	48.0	0.47	0.9	2.5	1.6	61	28.5								
2	Y3-112M2-16	2.34	2.22	2.14	0.37	0.5	315	48.5	0.47	0.9	2.5	1.6	64	36.6								
3	Y3-132M-16	3.2	3.0	2.9	0.55	0.75	330	54.0	0.48	0.9	2.7	1.6	64	46								
4	Y3-160M1-16	3.8	3.6	3.4	0.8	1	340	62.0	0.48	0.9	2.8	1.6	68	87.7								
5	Y3-160M2-16	5.4	5.1	4.9	1.1	1.5	345	64.0	0.48	0.9	2.8	1.6	68	108.4								
6	Y3-160L-16	7.1	6.7	8.5	1.5	2	345	66.0	0.48	0.9	2.8	1.6	70	146.7								
7	Y3-180M-16	9.4	8.9	8.6	2.2	3	350	71.5	0.49	0.9	3.2	1.6	70	0.2364								
8	Y3-180L-16	12.8	12.1	11.7	3	4	355	72.0	0.49	0.9	3.2	1.6	73	394.8								
9	Y3-200L1-16	16.4	15.6	15.0	4	5.5	355	74.0	0.50	0.9	3.2	1.6	73	571.8								
10	Y3-200L2-16	22.1	21.0	20.2	5.5	7.5	355	75.0	0.50	0.9	3.2	1.6	73	637								
11	Y3-225S-16	28.4	26.9	26.0	7.5	10	360	78.0	0.51	0.9	3.5	1.6	73	971.2								
12	Y3-250M-16	39.4	37.4	35.7	11	15	360	80.0	0.53	0.9	3.5	1.6	76	1921.5								
13	Y3-280M-16	49.8	47.3	45.6	15	20	360	82.0	0.55	1.0	3.5	1.6	76	2247.5								
14	Y3-315S-16	57.6	54.7	52.7	18.5	25	365	86.0	0.56	1.0	3.5	1.6	76	5578.1								
15	Y3-315M-16	68.1	64.6	62.3	22	30	365	87.0	0.56	1.0	3.5	1.6	82	6498.1								
16	Y3-315L1-16	91.7	87.1	83.9	30	40	365	88.0	0.56	1.0	3.5	1.6	82	7418.1								
17	Y3-315L2-16	112	106	102	38	50	365	88.0	0.56	1.0	3.5	1.6	82	8419.5								

MOUNTING DATA FOR Y3

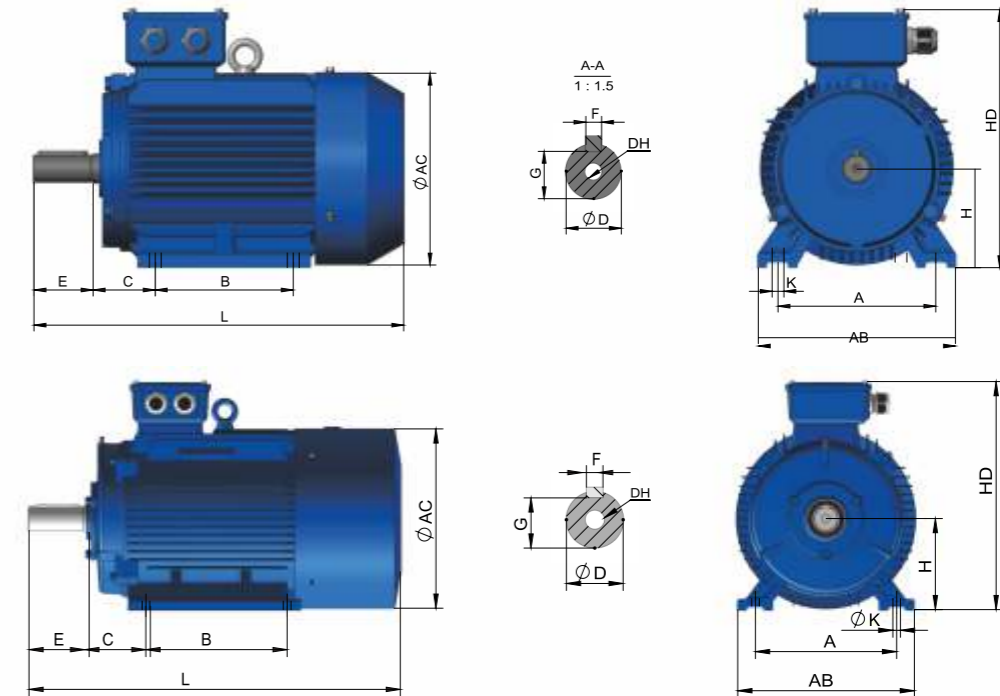

Frame with feet and end-shield without flange(IM B3)

FRAME SIZE	POLES	A	A/2	B	C	D	E	F	G	H	K	AB	AC	AD	HD	L	DH*
80M	2 4 6 8	125	62.5	100	50	19	40	6	15.5	80	10	165	155	145	220	295	M6X16
90S	2 4 6 8	140	70	100	56	24	50	8	20	90	10	180	175	155	250	320	M8X19
90L	2 4 6 8	140	70	125	56	24	50	8	20	90	10	180	175	155	250	345	M8X19
100L	2 4 6 8	160	80	140	63	28	60	8	24	100	12	205	196	180	270	385	M10X22
112M	2 4 6 8	190	95	140	70	28	60	8	24	112	12	230	220	190	300	400	M10X22
132S	2 4 6 8	216	108	140	89	38	80	10	33	132	12	270	259	210	345	470	M12X28
132M	2 4 6 8	216	108	178	89	38	80	10	33	132	12	270	259	210	345	510	M12X28
160M	2 4 6 8	254	127	210	108	42	110	12	37	160	15	320	315	255	420	615	M16X36
160L	2 4 6 8	254	127	254	108	42	110	12	37	160	15	320	315	255	420	660	M16X36
180M	2 4 6 8	279	139.5	241	121	48	110	14	42.5	180	15	355	355	280	455	700	M16X36
180L	2 4 6 8	279	139.5	279	121	48	110	14	42.5	180	15	355	355	280	455	740	M16X36
200L	2 4 6 8	318	159	305	133	55	110	16	49	200	19	395	397	305	505	770	M20X42
225S	4 8	356	178	286	149	60	140	18	53	225	19	435	445	335	560	815	M20X42
225M	2	356	178	311	149	55	110	16	49	225	19	435	445	335	560	820	M20X42
	4 6 8	356	178	311	149	60	140	18	53	225	19	435	445	335	560	845	M20X42
250M	2	406	203	349	168	60	140	18	53	250	24	490	485	370	615	920	M20X42
	4 6 8	406	203	349	168	65	140	18	58	250	24	490	485	370	615	920	M20X42
280S	2	457	228.5	368	190	65	140	18	58	280	24	550	547	410	680	995	M20X42
	4 6 8	457	228.5	368	190	75	140	20	67.5	280	24	550	547	410	680	995	M20X42
280M	2	457	228.5	419	190	65	140	18	58	280	24	550	547	410	680	1045	M20X42
	4 6 8	457	228.5	419	190	75	140	20	67.5	280	24	550	547	410	680	1045	M20X42
315S	2	508	254	406	216	65	140	18	58	315	28	635	620	530	845	1185	M20X42
	4 6 8 10	508	254	406	216	80	170	22	71	315	28	635	620	530	845	1220	M20X42
315M	2	508	254	457	216	65	140	18	58	315	28	635	620	530	845	1290	M20X42
	4 6 8 10	508	254	457	216	80	170	22	71	315	28	635	620	530	845	1325	M20X42
315L	2	508	254	508	216	65	140	18	58	315	28	635	620	530	845	1290	M20X42
	4 6 8 10	508	254	508	216	80	170	22	71	315	28	635	620	530	845	1325	M20X42
355M	2	610	305	560	254	75	140	20	67.5	355	28	730	698	655	1010	1500	M20X42
	4 6 8 10	610	305	560	254	95	170	25	86	355	28	730	698	655	1010	1530	M20X42
355L	2	610	305	630	254	75	140	20	67.5	355	28	730	698	655	1010	1500	M20X42
	4 6 8 10	610	305	630	254	95	170	25	86	355	28	730	698	655	1010	1530	M20X42

MOUNTING DATA FOR Y3

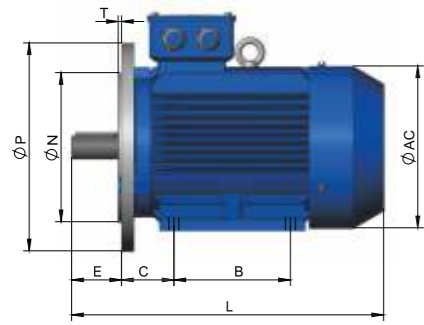

80-132

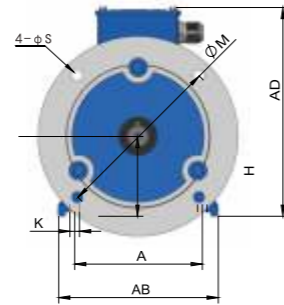
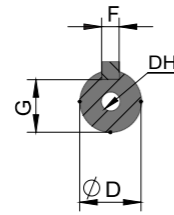

80-132

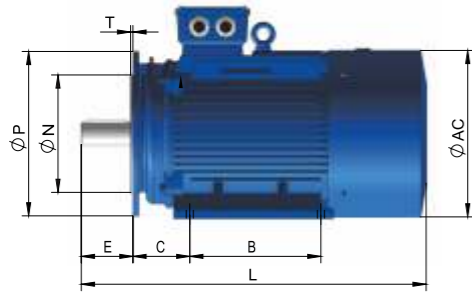

160-355

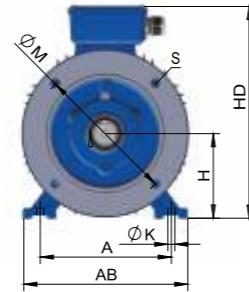
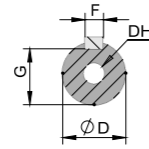

160-355

FRAME WITH FEET AND END-SHIELD WITH FLANGE(IM B35)

FRAME SIZE	POLES	A	A/2	B	C	D	E	F	G	H	K	M	N	P	S	T	FLANGE HOLES	AB	AC	AD	HD	L	DH*	
80M	2	468	125	62.5	100	50	19	40	6	15.5	80	10	165	130	200	12	3.5	4	165	155	145	220	295	M6X16
90S	2	468	140	70	100	56	24	50	8	20	90	10	165	130	200	12	3.5	4	180	175	155	250	320	M8X19
90L	2	468	140	70	125	56	24	50	8	20	90	10	165	130	200	12	3.5	4	180	175	155	250	345	M8X19
100L	2	468	160	80	140	63	28	60	8	24	100	12	215	180	250	15	4	4	205	196	180	270	385	M10X22
112M	2	468	190	95	140	70	28	60	8	24	112	12	215	180	250	15	4	4	230	220	190	300	400	M10X22
132S	2	468	216	108	140	89	38	80	10	33	132	12	265	230	300	14.5	4	4	270	259	210	345	470	M12X28
132M	2	468	216	108	178	89	38	80	10	33	132	12	265	230	300	14.5	4	4	270	259	210	345	510	M12X28
160M	2	468	254	127	210	108	42	110	12	37	160	15	300	250	350	19	5	4	320	315	255	420	615	M16X36
160L	2	468	254	127	254	108	42	110	12	37	160	15	300	250	350	19	5	4	320	315	255	420	660	M16X36
180M	2	468	279	139.5	241	121	48	110	14	42.5	180	15	300	250	350	19	5	4	355	355	280	455	700	M16X36
180L	2	468	279	139.5	279	121	48	110	14	42.5	180	15	300	250	350	19	5	4	355	355	280	455	740	M16X36
200L	2	468	318	159	305	133	55	110	16	49	200	19	350	300	400	19	5	4	395	397	305	505	770	M20X42
225S	4	356	178	286	149	60	140	18	53	225	19	400	350	450	19	5	8	435	445	335	560	815	M20X42	
225M	2	356	178	311	149	55	110	16	49	225	19	400	350	450	19	5	8	435	445	335	560	520	M20X42	
250M	2	406	203	349	168	60	140	18	53	225	19	400	350	450	19	5	8	435	445	335	560	845	M20X42	
250M	4	406	203	349	168	65	140	18	58	250	24	500	450	550	19	5	8	490	485	370	615	920	M20X42	
280S	2	457	228.5	358	190	65	140	18	58	280	24	500	450	550	19	5	8	550	547	410	680	995	M20X42	
280M	4	457	228.5	358	190	75	140	20	67.5	280	24	500	450	550	19	5	8	550	547	410	680	995	M20X42	
280M	2	457	228.5	419	190	65	140	18	58	280	24	500	450	550	19	5	8	550	547	410	680	1045	M20X42	
315S	2	508	254	406	216	65	140	18	58	315	28	600	550	660	24	6	8	635	620	530	845	1185	M20X42	
315M	4	508	254	406	216	80	170	22	71	315	28	600	550	660	24	6	8	635	620	530	845	1220	M20X42	
315M	2	508	254	457	216	65	140	18	58	315	28	600	550	660	24	6	8	635	620	530	845	1290	M20X42	
315L	4	508	254	457	216	80	170	22	71	315	28	600	550	660	24	6	8	635	620	530	845	1325	M20X42	
315L	2	508	254	508	216	65	140	18	58	315	28	600	550	660	24	6	8	635	620	530	845	1290	M20X42	
355M	4	610	305	560	254	75	140	20	67.5	355	28	740	680	800	24	6	8	730	698	655	1010	1500	M20X42	
355M	2	610	305	560	254	95	170	25	86	355	28	740	680	800	24	6	8	730	698	655	1010	1530	M20X42	
355L	4	610	305	630	254	75	140	20	67.5	355	28	740	680	800	24	6	8	730	698	655	1010	1500	M20X42	
355L	2	610	305	630	254	95	170	25	86	355	28	740	680	800	24	6	8	730	698	655	1010	1530	M20X42	

MOUNTING DATA FOR Y3

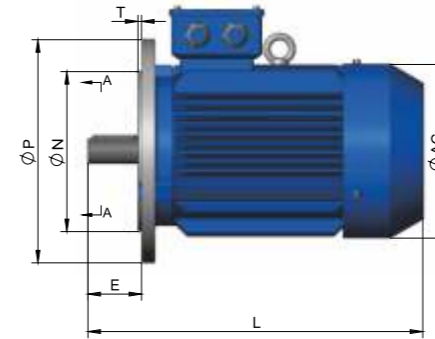

80-132

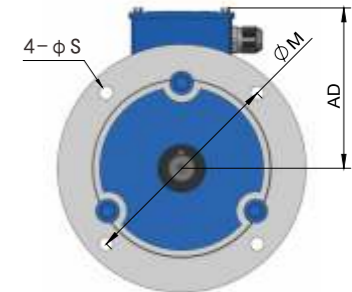
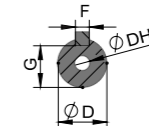

80-132



160-355

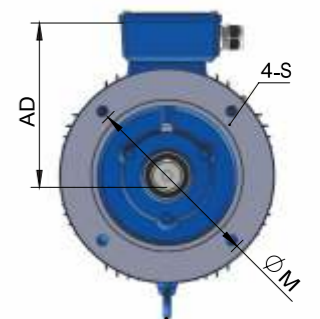
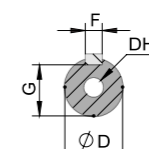

160-355

FRAME WITHOUT FEET AND END-SHIELD WITH FLANGE(IM B5)

FRAME SIZE	POLES	D	E	F	G	M	N	P	S	T	FLANGE HOLES	AC	AD	HF	L	DH*	
80M	2	468	19	40	6	15.5	165	130	200	12	3.5	4	155	145	185	295	M6X16
90S	2	468	24	50	8	20	165	130	200	12	3.5	4	175	155	195	320	M8X19
90L	2	468	24	50	8	20	165	130	200	12	3.5	4	175	155	195	345	M8X19
100L	2	468	28	60	8	24	215	180	250	15	4	4	196	180	245	385	M10X22
112M	2	468	28	60	8	24	230	180	250	15	4	4	220	190	265	400	M10X22
132S	2	468	38	80	10	33	265	230	300	15	4	4	259	210	315	470	M12X28
132M	2	468	38	80	10	33	265	230	300	15	4	4	259	210	315	510	M12X28
160M	2	468	42	110	12	37	300	250	350	19	5	4	315	255	385	615	M16X36
160L	2	468	42	110	12	37	300	250	350	19	5	4	315	255	385	660	M16X36
180M	2	468	48	110	14	42.5	300	250	350	19	5	4	355	280	430	700	M16X36
180L	2	468	48	110	14	42.5	300	250	350	19	5	4	355	280	430	740	M16X36
200L	2	468	55	110	16	49	350	300	400	19	5	4	397	305	480	770	M20X42
225S	4	356	140	18	53	400	350	450	19	5	8	445	335	535	815	M20X42	
225M	2	356	140	18	49	400	350	450	19	5	8	445	335	535	820	M20X42	
250M	2	406	140	18	53	400	350	450	19	5	8	445	335	535	845	M20X42	
250M	4	406	140	18	58	500	450	550	19	5	8	485	370	595	920	M20X42	
280S	2	457	140	18	58	500	450	550	19	5	8	547	410	650	995	M20X42	
280M	4	457	140	18	67.5	500	450	550	19	5	8	547	410	650	995	M20X42	
280M	2	457	140	18	58	500	450	550	19	5	8	547	410	650	1045	M20X42	
315S	2	508	140	18	58	600	550	660	24	6	8	620	530	845	1185	M20X42	
315M	4	508	140	18	71	600	550	660	24	6	8	620	530	845	1220	M20X42	
315M	2	508	140	18	58	600	550	660	24	6	8	620	530	845	1290	M20X42	
315L	4	508	140	18	71	600	550	660	24	6	8	620	530	845	1325	M20X42	
315L	2	508	140	18	58	600	550	660	24	6	8	620	530	845	1290	M20X42	
355M	4	610	140	20	67.5	740	680	800	24	6	8	698	655	1010	1500	M20X42	
355M	2	610	140	20	86	740	680	800	24	6	8	698	655	1010	1530	M20X42	
355L	4	610	140	20	67.5	740	680	800	24	6	8	698	655	1010	1500	M20X42	
355L	2	610	140	20	86	740	680	800	24	6	8	698	655	1010	1530	M20X42	

MOUNTING DATA FOR Y3

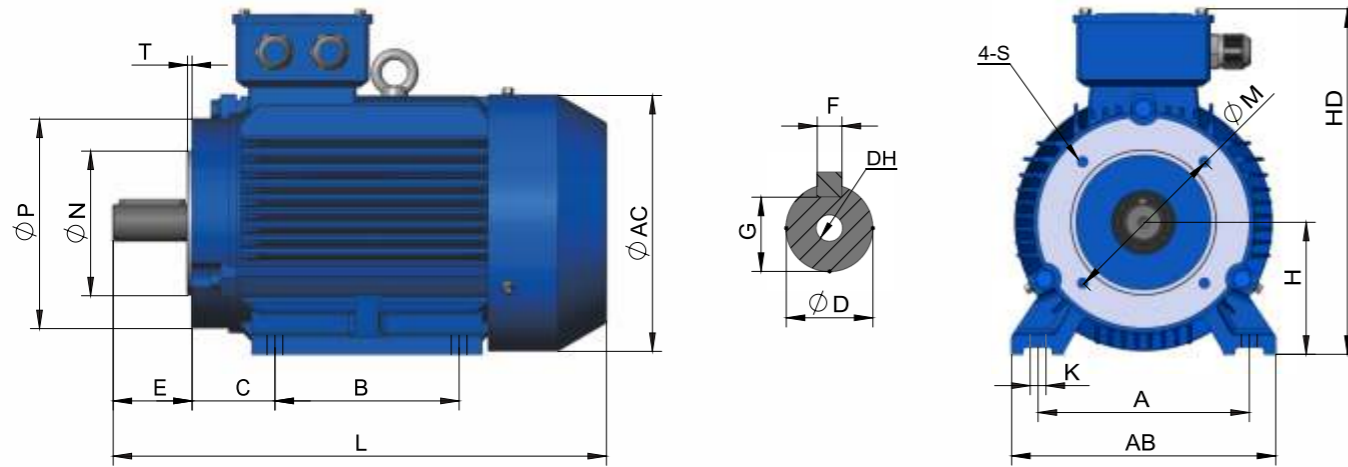

80-132

80-132

FRAME WITH FEET AND END-SHIELD WITH FLANGE (IM B34)

FRAME SIZE	POLES	A	A/2	B	C	D	E	F	G	H	K	M	N	P	R*	S	T	FLANGE HOLES	AB	AC	AD	HD	L
80	2 4 6 8	125	62.5	100	50	19	40	6	15.5	80	10	100	80	120	0	M6	3.0	4	165	155	145	214	295
90S	2 4 6 8	140	70	100	56	24	50	8	20	90	10	115	95	140	0	M8	3.0	4	180	175	155	250	320
90L	2 4 6 8	140	70	125	56	24	50	8	20	90	10	115	95	140	0	M8	3.0	4	180	175	155	250	345
100L	2 4 6 8	160	80	140	63	28	60	8	24	100	12	130	110	160	0	M8	3.5	4	205	196	180	270	385
112M	2 4 6 8	190	95	140	70	28	60	8	24	112	12	130	110	160	0	M8	4	4	230	220	190	300	400
132S	2 4 6 8	216	108	140	89	38	80	10	33	132	12	165	130	200	0	M10	4	4	270	259	210	345	470
132M	2 4 6 8	216	108	178	89	38	80	10	33	132	12	165	130	200	0	M10	4	4	270	259	210	345	510

MOUNTING DATA FOR Y3

FRAME WITHOUT FEET AND END-SHIELD WITHOUT FLANGE (IM B14)

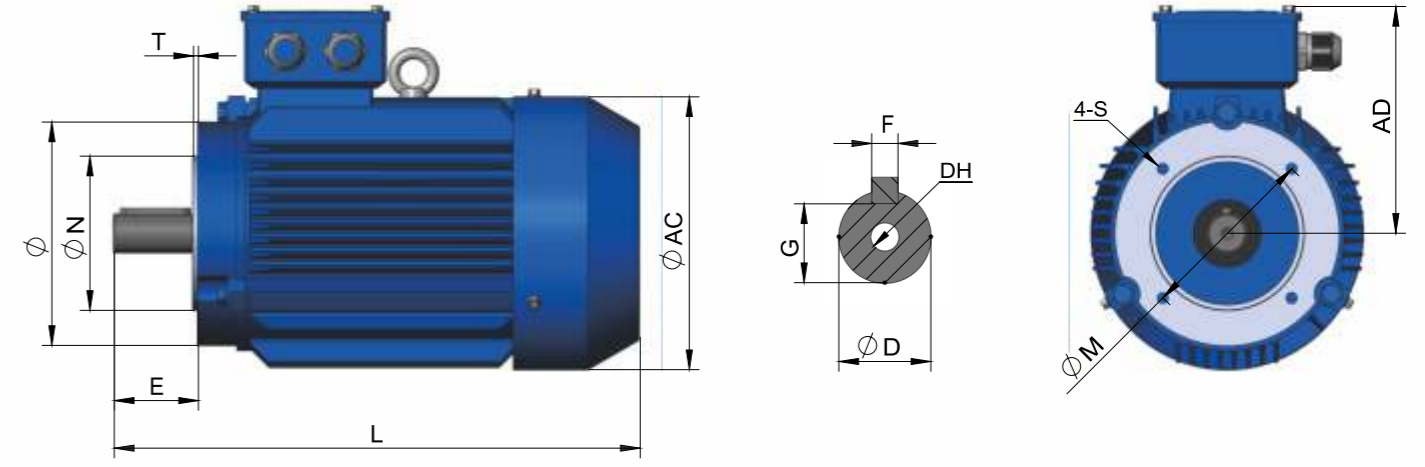

FRAME SIZE	POLES	D	E	F	G	M	N	P	R*	S	T	FLANGE HOLES	AC	AD	HF	L
80	2 4 6 8	19	40	6	15.5	100	80	120	0	M6	3.0	4	155	145	185	295
90S	2 4 6 8	24	50	8	20	115	95	140	0	M8	3.0	4	175	155	195	320
90L	2 4 6 8	24	50	8	20	115	95	140	0	M8	3.0	4	175	155	195	345
100L	2 4 6 8	28	60	8	24	130	110	160	0	M8	3.5	4	196	180	245	385
112M	2 4 6 8	28	60	8	24	130	110	160	0	M8	3.5	4	220	190	265	400
132S	2 4 6 8	38	80	10	33	165	130	200	0	M10	3.5	4	259	210	315	470
132M	2 4 6 8	38	80	10	33	165	130	200	0	M10	3.5	4	259	210	315	510

**FRAME TYPE, FRAME WITHOUT FEET AND END SHIELD
WITH FLANGE (WITH PLAIN HOLES) (IM V1)**

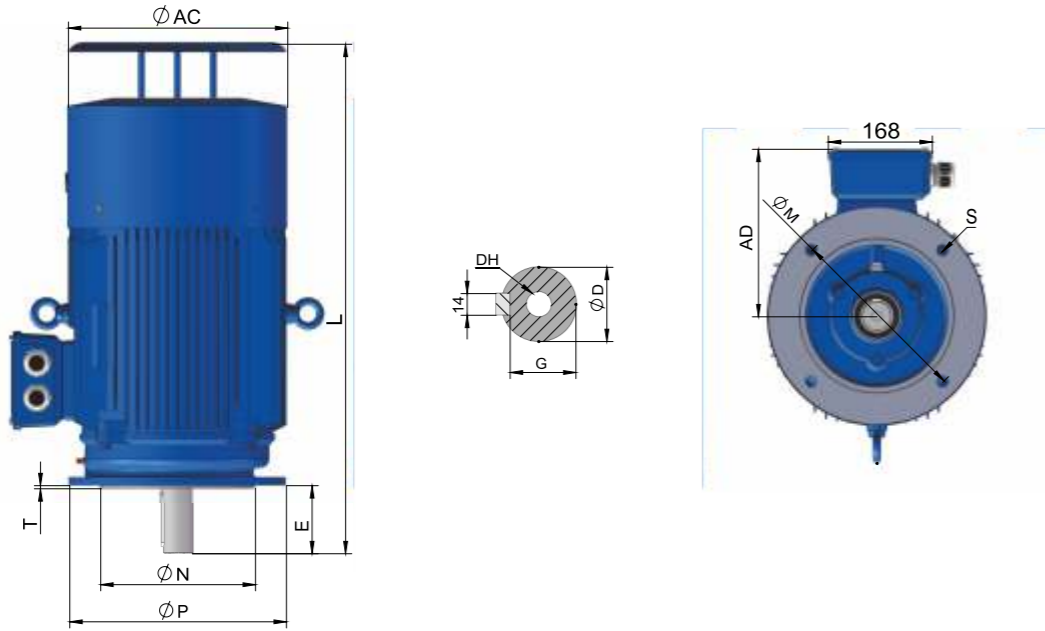

FRAME SIZE	POLES	D	E	F	M	N	P	S	T	FLANGE HOLES	AC	AD	HF	L
160M	2 4 6 8	42	110	12	300	250	350	19	5	4	315	255	455	695
160L	2 4 6 8	42	110	12	300	250	350	19	5	4	315	255	455	740
180M	2 4 6 8	48	110	14	300	250	350	19	5	4	355	280	500	790
180L	2 4 6 8	48	110	14	300	250	350	19	5	4	355	280	500	830
200L	2 4 6 8	55	110	16	350	300	400	19	5	4	397	305	550	860
225S	4 8	60	140	18	400	350	450	19	5	8	445	335	610	905
225M	2	55	110	16	400	350	450	19	5	8	445	335	610	910
	4 6 8	60	140	18	400	350	450	19	5	8	445	335	610	935
250M	2	60	140	18	500	450	550	19	5	8	485	370	650	1015
	4 6 8	65	140	18	500	450	550	19	5	8	485	370	650	1015
280S	2	65	140	18	500	450	550	19	5	8	547	410	720	1110
	4 6 8	75	140	20	500	450	550	19	5	8	547	410	720	1110
280M	2	65	140	18	500	450	550	19	5	8	547	410	720	1150
	4 6 8	75	140	20	500	450	550	19	5	8	547	410	900	1150
315S	2	65	140	18	600	550	660	24	6	8	620	530	900	1280
	4 6 8 10	80	170	22	600	550	660	24	6	8	620	530	900	1310
315M	2	65	140	18	600	550	660	24	6	8	620	530	900	1380
	4 6 8 10	80	170	22	600	550	660	24	6	8	620	530	900	1430
315L	2	65	140	18	600	550	660	24	6	8	620	530	900	1380
	4 6 8 10	80	170	22	600	550	660	24	6	8	620	530	900	1430
355M	2	75	140	20	740	680	800	24	6	8	698	655	1010	1640
	4 6 8 10	95	170	25	740	680	800	24	6	8	698	655	1010	1670
355L	2	75	140	20	740	680	800	24	6	8	698	655	1010	1640
	4 6 8 10	95	170	25	740	680	800	24	6	8	698	655	1010	1670

Y3EJ

THREE-PHASE ASYNCHRONOUS MOTOR

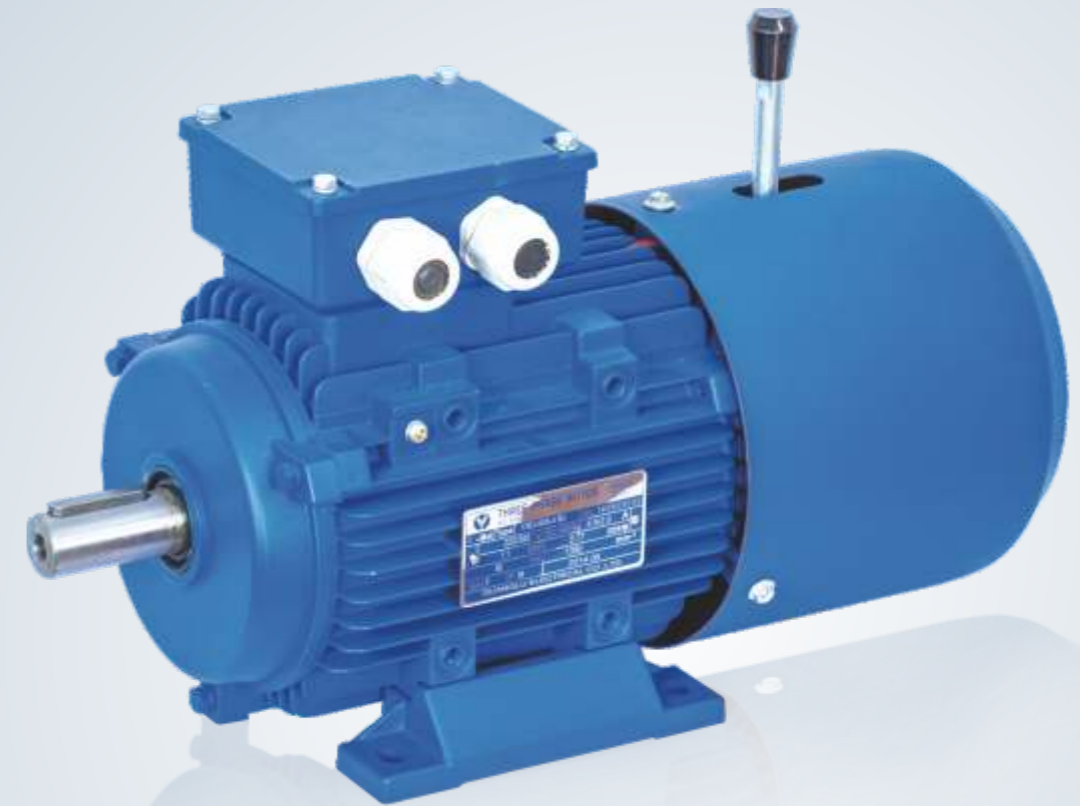

Y3VP THREE-PHASE ASYNCHRONOUS MOTOR



TECHNICAL DATA OF Y3VP SERIES

NO.	Frame reference and size	Rated power (Kw)	Full load current at rated voltage (A)	Rated torque (N.m)	Frequency at constant torque (Hz)	Frequency at constant power (Hz)	Direct on line starting torque ratio	Direct on line starting current ratio	Direct on line pull out torque ratio
							LRT/RLT	LRA/RLA	BDT/RLT
1	80M1-4	0.55	1.5	3.5	5-50	50-100	2.4	5.2	2.3
2	80M2-4	0.75	2	4.7	5-50	50-100	2.3	6.0	2.3
3	90S-4	1.1	2.8	7	5-50	50-100	2.3	6.0	2.3
4	90L-4	1.5	3.7	9.5	5-50	50-100	2.3	6.0	2.3
5	100L1-4	2.2	5.1	14	5-50	50-100	2.3	7.0	2.3
6	100L2-4	3	6.8	19	5-50	50-100	2.3	7.0	2.3
7	112M-4	4	8.7	25.4	5-50	50-100	2.3	7.0	2.3
8	132S-4	5.5	11.4	35	5-50	50-100	2.3	7.0	2.3
9	132M-4	7.5	15.3	47.7	5-50	50-100	2.3	7.0	2.3
10	160M-4	11	22.1	70	5-50	50-100	2.2	7.0	2.3
11	160L-4	15	30.1	95.5	5-50	50-100	2.2	7.5	2.3
12	180M-4	18.5	35.4	117.1	5-50	50-100	2.2	7.5	2.3
13	180L-4	22	41.6	140.9	5-50	50-100	2.2	7.5	2.3
14	200L-4	30	55.9	190.9	5-50	50-100	2.2	7.2	2.3
15	225S-4	37	68.2	235.5	5-50	50-100	2.2	7.2	2.3
16	225M-4	45	82.5	286.4	5-50	50-100	2.2	7.2	2.3
17	250M-4	55	101	350.1	3-50	50-100	2.2	7.2	2.3
18	280S-4	75	132.3	477.1	3-50	50-100	2.2	6.8	2.3
19	280M-4	90	157.4	572.9	3-50	50-100	2.2	6.8	2.3
20	315S-4	110	191.4	700.2	3-50	50-100	2.1	6.9	2.2
21	315M-4	132	227.6	840.3	3-50	50-100	2.1	6.9	2.2
22	315L1-4	160	274.2	1018.5	3-50	50-100	2.1	6.9	2.2
23	315L2-4	200	341.6	1273.2	3-50	50-100	2.1	6.9	2.2

Y3D

THREE-PHASE ASYNCHRONOUS MOTOR



TECHNICAL DATA OF Y3D SERIES

Frame reference and size		Rated power	Full load current at rated voltage	Full load speed in revolutions per minute	Efficiency	Power factor	Direct on line starting torque ratio	Direct on line starting current ratio	Direct on line pull out torque ratio
Type	Poles	Output (kw)	Amps (A)	Speed (r/min)	η (%)	Power factor (cos ϕ)	LRT/RLT	LRA/RLA	BDT/RLT
801-	4	0.45	1.4	1420	66	0.74	1.5	6.5	1.8
	2	0.55	1.5	2860	65	0.85	1.7	7	1.8
802-	4	0.55	1.7	1420	68	0.74	1.6	6.5	1.8
	2	0.75	2.0	2860	66	0.85	1.8	7	1.8
90S-	4	0.85	2.3	1430	74	0.77	1.8	6.5	1.8
	2	1.1	2.8	2850	71	0.85	1.9	7	1.8
90L-	4	1.3	3.3	1430	76	0.78	1.8	6.5	1.8
	2	1.8	4.3	2850	73	0.85	2.0	7	1.8
100L1-	4	2	4.8	1430	78	0.81	1.7	6.5	1.8
	2	2.4	5.6	2850	76	0.86	1.9	7	1.8
100L2-	4	2.4	5.6	1430	79	0.83	1.6	6.5	1.8
	2	3.0	6.7	2850	77	0.89	1.7	7	1.8
112M-	4	3.3	7.4	1450	82	0.83	1.9	6.5	1.8
	2	4.0	8.6	2860	79	0.89	2.0	7	1.8
132S-	4	4.5	9.8	1450	83	0.84	1.7	6.5	1.8
	2	5.5	11.9	2860	79	0.89	1.8	7	1.8
132M-	4	6.5	13.8	1450	84	0.85	1.7	6.5	1.8
	2	8	17.1	2880	80	0.89	1.8	7	1.8
160M-	4	9	18.5	1460	87	0.85	1.6	6.5	1.8
	2	11	22.9	2920	82	0.89	1.8	7	1.8
160L-	4	11	22.3	1460	87	0.86	1.7	6.5	1.8
	2	14	28.8	2920	82	0.90	1.9	7	1.8
180M-	4	15	29.4	1470	89	0.87	1.8	6.5	1.8
	2	18.5	36.7	2940	85	0.90	1.9	7	1.8
180L-	4	18.5	35.9	1470	89	0.88	1.6	6.5	1.8
	2	22	42.7	2940	86	0.91	1.8	7	1.8
200L-	4	26	49.9	1470	89	0.89	1.4	6.5	1.8
	2	30	58.3	2950	85	0.92	1.6	7	1.8
225S-	4	32	60.7	1480	90	0.89	1.4	6.5	1.8
	2	37	71.7	2960	86	0.92	1.6	7	1.8
225M-	4	37	69.4	1480	91	0.89	1.6	6.5	1.8
	2	45	86.4	2960	86	0.92	1.6	7	1.8

TECHNICAL DATA OF Y3D SERIES

Frame reference and size		Rated power	Full load current at rated voltage	Full load speed in revolutions per minute	Efficiency	Power factor	Direct on line starting torque ratio	Direct on line starting current ratio	Direct on line pull out torque ratio
Type	Poles	Output (kw)	Amps (A)	Speed (r/min)	η (%)	Power factor (cos ϕ)	LRT/RLT	LRA/RLA	BDT/RLT
250M-	4	45	84.4	1480	91	0.89	1.6	6.5	1.8
	2	52	103.2	2960	87	0.92	1.6	7	1.8
280S-	4	60	111.3	1480	91	0.90	1.4	6.5	1.8
	2	72	135.1	2970	88	0.92	1.5	7	1.8
280M-	4	72	133.6	1480	91	0.90	1.4	6.5	1.8
	2	82	152.2	2970	88	0.93	1.5	7	1.8
90S-	6	0.65	2.2	920	64	0.68	1.6	6	1.8
	4	0.85	2.3	1420	70	0.79	1.4	6.5	1.8
90L-	6	0.85	2.8	930	66	0.70	1.6	6	1.8
	4	1.1	3.0	1420	71	0.79	1.5	6.5	1.8
100L1-	6	1.3	3.8	940	74	0.70	1.7	6	1.8
	4	1.8	4.4	1440	77	0.80	1.4	6.5	1.8
100L2-	6	1.5	4.3	940	75	0.70	1.6	6	1.8
	4	2.2	5.4	1440	77	0.80	1.4	6.5	1.8
112M-	6	2.2	5.7	960	78	0.75	1.8	6	1.8
	4	2.8	6.7	1440	77	0.82	1.5	6.5	1.8
132S-	6	3	7.7	960	79	0.75	1.8	6	1.8
	4	4	9.5	1440	78	0.82	1.7	6.5	1.8
132M-	6	4	9.8	960	82	0.76	1.6	6	1.8
	4	5.5	12.3	1440	80	0.85	1.4	6.5	1.8
160M-	6	6.5	15.1	970	84	0.78	1.5	6	1.8
	4	8	17.4	1460	82	0.84	1.5	6.5	1.8
160L-	6	9	20.6	970	85	0.78	1.6	6	1.8
	4	11	23.4	1460	83	0.85	1.7	6.5	1.8
180M-	6	11	25.9	980	85	0.76	1.6	6	1.8
	4	14	29.8	1470	84	0.85	1.7	6.5	1.8
180L-	6	13	29.4	980	86	0.78	1.7	6	1.8
	4	16	33.6	1470	85	0.85	1.7	6.5	1.8
200L-	6	18.5	41.4	980	87	0.78	1.6	6.7	1.8
	4	22	44.7	1460	86.5	0.86	1.5	7.0	1.8
225S-	6	22	44.2	980	88	0.86	1.8	6.5	1.8
	4	28	56.2	1470	86.5	0.87	1.8	7	1.8

TECHNICAL DATA OF Y3D SERIES

Frame reference and size		Rated power	Full load current at rated voltage	Full load speed in revolutions per minute	Efficiency	Power factor	Direct on line starting torque ratio	Direct on line starting current ratio	Direct on line pull out torque ratio
Type	Poles	Output (kw)	Amps (A)	Speed (r/min)	η (%)	Power factor (cos ϕ)	LRT/RLT	LRA/RLA	BDT/RLT
225M-	6	26	52.2	980	88	0.86	1.8	6.5	1.8
	4	32	66.0	1470	85.5	0.90	1.8	7	1.8
250M-	6	32	62.1	980	90	0.87	1.5	6.5	1.8
	4	42	74.7	1470	86.5	0.91	1.3	7	1.8
280S-	6	42	81.5	980	90	0.87	1.5	6.5	1.8
	4	55	104.2	1470	87	0.90	1.3	7	1.8
280M-	6	55	106.7	990	90	0.87	1.6	6.5	1.8
	4	67	138.1	1480	87	0.89	1.3	7	1.8
90L-	8	0.45	1.9	680	58	0.63	1.6	5.5	1.8
	4	0.75	1.92	1420	72	0.87	1.4	6.5	1.8
100L-	8	0.85	3.1	700	67	0.63	1.6	5.5	1.8
	4	1.5	3.5	1420	74	0.88	1.4	6.5	1.8
112M-	8	1.5	5.0	700	72	0.63	1.7	5.5	1.8
	4	2.4	5.3	1420	78	0.88	1.7	6.5	1.8
132S-	8	2.2	7.0	720	75	0.64	1.5	5.5	1.8
	4	3.3	7.1	1440	80	0.88	1.7	6.5	1.8
132M-	8	3	9.0	720	78	0.65	1.5	5.5	1.8
	4	4.5	9.4	1440	82	0.89	1.6	6.5	1.8
160M-	8	5	13.9	730	83	0.66	1.5	5.5	1.8
	4	7.5	15.2	1450	84	0.89	1.6	6.5	1.8
160L-	8	7	19.0	730	85	0.66	1.5	5.5	1.8
	4	11	21.8	1450	86	0.89	1.6	6.5	1.8
180L-	8	11	26.0	730	87	0.72	1.5	6	1.8
	4	17	31.5	1470	88	0.91	1.5	7	1.8
200L1-	8	14	33.0	740	87	0.74	1.8	6	1.8
	4	22	41.3	1470	88	0.92	1.7	7	1.8
200L2-	8	17	40.1	740	87	0.74	1.5	6	1.8
	4	26	48.8	1470	88	0.92	1.7	7	1.8
225M-	8	24	53.2	740	89	0.77	1.5	6	1.8
	4	34	66.7	1470	88	0.88	1.5	7	1.8

TECHNICAL DATA OF Y3D SERIES

Frame reference and size		Rated power	Full load current at rated voltage	Full load speed in revolutions per minute	Efficiency	Power factor	Direct on line starting torque ratio	Direct on line starting current ratio	Direct on line pull out torque ratio
Type	Poles	Output (kw)	Amps (A)	Speed (r/min)	η (%)	Power factor (cos ϕ)	LRT/RLT	LRA/RLA	BDT/RLT
250M-	8	30	64.9	740	90	0.78	1.6	6	1.8
	4	42	78.8	1480	89	0.91	1.7	7	1.8
280S-	8	40	83.5	740	91	0.80	1.6	6	1.8
	4	55	102	1480	90	0.91	1.7	7	1.8
280M-	8	47	96.9	740	91	0.81	1.6	6	1.8
	4	67	122.9	1480	90	0.92	1.7	7	1.8
90S-	8	0.35	1.6	680	56	0.60	1.8	5	1.8
	6	0.45	1.4	930	70	0.72	1.2	6	1.8
90L-	8	0.45	1.9	680	59	0.60	1.7	5	1.8
	6	0.65	1.9	930	71	0.73	1.8	6	1.8
100L-	8	0.75	2.9	710	65	0.60	1.8	5	1.8
	6	1.1	3.1	950	75	0.73	1.9	6	1.8
112M-	8	1.3	4.5	710	72	0.61	1.7	5	1.8
	6	1.8	4.8	950	78	0.73	1.9	6	1.8
132S-	8	1.8	5.8	730	76	0.62	1.6	5	1.8
	6	2.4	6.2	970	80	0.73	1.9	6	1.8
132M-	8	2.6	8.2	730	78	0.62	1.9	5	1.8
	6	3.7	9.4	970	82	0.73	1.9	6	1.8
160M-	8	4.5	13.3	930	83	0.62	1.6	5	1.8
	6	6	14.7	980	85	0.73	1.9	6	1.8
160L-	8	6	17.5	930	84	0.62	1.6	5	1.8
	6	8	19.4	980	86	0.73	1.9	6	1.8
180M-	8	7.5	21.9	930	84	0.62	1.9	5	1.8
	6	10	24.2	980	86	0.73	1.9	6	1.8
180L-	8	9	24.8	730	85	0.65	1.8	5	1.8
	6	12	28.3	980	86	0.75	1.8	6	1.8
200L1-	8	12	32.5	730	86	0.65	1.8	5	1.8
	6	17	39.1	980	87	0.76	2.0	6	1.8
200L2-	8	15	40.3	730	87	0.65	1.8	5	1.8
	6	20	45.4	980	88	0.76	2.0	6	1.8

Y3DT

THREE-PHASE
ASYNCHRONOUS MOTOR



TECHNICAL DATA OF Y3DT SERIES

Frame reference and size		Rated power	Full load current at rated voltage	Efficiency	Power factor	Direct on line starting torque ratio	Direct on line pull out torque ratio	Direct on line starting current ratio
Type	Poles	Output (kw)	Amps (A)	η (%)	Power factor (cos ϕ)	LRT/RLT	BDT/RLT	LRA/RLA
80M1	2	0.75	1.86	68	0.82	2.0	1.8	7.5
	4	0.17	0.65	58	0.62	1.4	1.8	5.5
80M2	2	0.95	2.33	70	0.81	2.0	1.8	7.5
	4	0.25	0.87	64	0.65	1.4	1.8	5.5
90S	2	1.4	3.45	71	0.83	2.0	1.8	7.5
	4	0.3	0.85	70	0.72	1.4	1.8	5.5
90L	2	1.9	4.27	75	0.86	2.0	1.8	7.5
	4	0.4	1.08	72	0.73	1.4	1.8	5.5
100L1	2	2.5	5.25	82	0.87	2.0	1.8	7.5
	4	0.65	1.80	74	0.72	1.4	1.8	5.5
100L2	2	3.1	6.39	82	0.87	2.0	1.8	7.5
	4	0.8	2.17	76	0.72	1.4	1.8	5.5
112M	2	4.4	9.15	82	0.88	2.0	1.8	7.5
	4	1.1	2.42	80	0.74	1.4	1.8	5.5
132S	2	5.9	11.68	83	0.91	1.9	1.8	7.5
	4	1.4	3.5	80	0.74	1.3	1.8	5.5
132M	2	8	15.29	85	0.91	1.9	1.8	7.5
	4	2	4.65	83	0.77	1.3	1.8	5.5
160M	2	12.5	24.04	86	0.91	1.9	1.8	7.5
	4	2.8	6.56	85	0.75	1.3	1.8	5.5
160L	2	16.5	30.98	87	0.91	1.9	1.8	7.5
	4	3.8	8.64	86	0.76	1.3	1.8	5.5
90S	4	1.1	2.86	70	0.78	1.8	1.8	7
	6	0.32	1.09	63	0.66	1.6	1.8	6
90L	4	1.4	3.4	72	0.81	1.8	1.8	7
	6	0.45	1.43	68	0.66	1.6	1.8	6
100L1	4	2.2	5.22	80	0.79	1.8	1.8	7
	6	0.7	2.15	73	0.66	1.6	1.8	6
100L2	4	2.5	5.96	81	0.78	1.8	1.8	7
	6	0.9	2.86	74	0.67	1.6	1.8	6
112M	4	3.2	7.03	82	0.82	1.8	1.8	7
	6	1.1	3.09	78	0.68	1.6	1.8	6
132S	4	4.7	10	84	0.83	1.8	1.8	7
	6	1.5	4.06	81	0.68	1.6	1.8	6
132M	4	6.7	13.71	85	0.85	1.8	1.8	7
	6	2.2	5.7	83	0.69	1.6	1.8	6
160M	4	9.5	19.3	87	0.84	1.8	1.8	7.5
	6	3.1	7.91	83	0.69	1.6	1.8	7
160L	4	12	24.36	88	0.84	1.8	1.8	7.5
	6	4	10	83	0.69	1.6	1.8	7
180M	4	15.5	31.4	87	0.84	1.5	1.8	7.5
	6	5.1	12.06	81	0.72	1.5	1.8	7
180L	4	18	37.14	87	0.85	1.5	1.8	7.5
	6	6.2	14.33	81	0.74	1.5	1.8	7
200L	4	24	48.2	88	0.85	1.5	1.8	7.5
	6	8.5	19.1	83	0.77	1.5	1.8	7
225S	4	33	60.7	89	0.86	1.5	1.8	7.5
	6	11	8.2	84	0.84	1.5	1.8	7

TECHNICAL DATA OF Y3DT SERIES

Frame reference and size		Rated power	Full load current at rated voltage	Efficiency	Power factor	Direct on line starting torque ratio	Direct on line pull out torque ratio	Direct on line starting current ratio
Type	Poles	Output (kw)	Amps (A)	η (%)	Power factor (cos Φ)	LRT/RLT	BDT/RLT	LRA/RLA
225M	4	38	71.3	90	0.86	1.5	1.8	7.5
	6	13	27.3	85	0.85	1.5	1.8	7
250M	4	47	84.2	90	0.89	1.5	1.8	7.5
	6	16	32.3	85	0.87	1.5	1.8	7
280S	4	55	99.6	90	0.88	1.5	1.8	7.5
	6	18.5	37.3	85	0.86	1.5	1.8	7
280M1	4	70	125	91	0.88	1.5	1.8	7.5
	6	25	48.4	87	0.87	1.5	1.8	7
280M2	4	84	150.6	91	0.88	1.5	1.8	7.5
	6	28	54.8	87	0.87	1.5	1.8	7
315S	4	95	177.4	91	0.86	1.5	1.8	7.5
	6	32	65.3	89	0.79	1.5	1.8	7
315M	4	115	217.5	92	0.86	1.5	1.8	7.5
	6	38	77.9	90	0.78	1.5	1.8	7
315L1	4	135	260	92	0.86	1.5	1.8	7.5
	6	45	90.5	90	0.80	1.5	1.8	7
315L2	4	160	294	93	0.86	1.5	1.8	7.5
	6	55	113.4	91	0.80	1.5	1.8	7
90S	4	1.0	2.44	70	0.82	1.9	1.8	7.5
	8	0.22	0.92	55	0.62	1.5	1.8	5
90L	4	1.3	3.10	72	0.82	1.9	1.8	7.5
	8	0.3	1.18	58	0.63	1.5	1.8	5
100L1	4	2.0	4.68	80	0.80	1.9	1.8	7.5
	8	0.55	0.55	65	0.61	1.5	1.8	5
100L2	4	2.4	5.48	80	0.81	1.9	1.8	7.5
	8	0.65	2.37	66	0.61	1.5	1.8	5
112M	4	3.2	7.4	71	0.78	1.9	1.8	7.5
	8	0.9	3.24	84	0.59	1.5	1.8	5
132S	4	4.5	9.68	75	0.82	2.0	1.8	7.5
	8	1.1	3.68	85	0.59	1.2	1.8	5
132M	4	6.3	13.13	78	0.83	2.0	1.8	7.5
	8	1.5	4.84	85	0.59	1.2	1.8	5
160M	4	8.9	18.14	82	0.85	2.0	1.8	7.5
	8	2.0	5.34	86	0.67	1.2	1.8	5
160L	4	12	23.47	84	0.86	2.0	1.8	7.5
	8	2.7	6.9	88	0.67	1.2	1.8	5
180M	4	16	31.77	84	0.85	2.0	1.8	7.5
	8	4	10.83	89	0.65	1.2	1.8	5
180L	4	19.5	38.56	85	0.85	2.0	1.8	7.5
	8	5	13.32	90	0.66	1.2	1.8	5
200L	4	29	56.8	87	0.85	2.0	1.8	7.5
	8	7.5	19.57	91	0.66	1.2	1.8	5
225M	4	40	74.57	88	0.88	2.0	1.8	7.5
	8	9.5	25.43	91	0.64	1.3	1.8	5
250M	4	52	97.29	88	0.87	2.0	1.8	7.5
	8	14.5	36.97	88	0.66	1.3	1.8	5
280S	4	65	122.74	91	0.87	2.0	1.8	7.5
	8	17	41.73	89	0.68	1.3	1.8	5

TECHNICAL DATA OF Y3DT SERIES

Frame reference and size		Rated power	Full load current at rated voltage	Efficiency	Power factor	Direct on line starting torque ratio	Direct on line pull out torque ratio	Direct on line starting current ratio
Type	Poles	Output (kw)	Amps (A)	η (%)	Power factor (cos Φ)	LRT/RLT	BDT/RLT	LRA/RLA
280M	4	75	137.39	91	0.88	2.0	1.8	7.5
	8	18.5	43.86	90	0.70	1.3	1.8	5
315S	4	92	174.76	91	0.86	2.0	1.8	7.5
	8	25	58.71	90	0.70	1.3	1.8	5
315M	4	110	208.26	92	0.86	2.0	1.8	7.5
	8	30	70.11	91	0.70	1.3	1.8	5
315L1	4	135	253.26	92	0.87	2.0	1.8	7.5
	8	36	83.99	91	0.70	1.3	1.8	5
315L2	4	155	287.97	92	0.87	2.0	1.8	7.5
	8	41	94.72	91	0.71	1.3	1.8	5
90S	6	0.65	2.24	65	0.63	1.8	1.8	7
	8	0.25	1.22	52	0.58	1.6	1.8	6
90L	6	0.80	2.87	67	0.62	1.8	1.8	7
	8	0.35	1.58	56	0.58	1.6	1.8	6
100L1	6	1.3	4.07	71	0.66	1.8	1.8	7
	8	0.55	2.23	62	0.58	1.6	1.8	6
100L2	6	1.6	3.11	74	0.67	1.8	1.8	7
	8	0.75	2.86	66	0.59	1.6	1.8	6
112M	6	2.0	6.0	74	0.70	1.8	1.8	7
	8	0.85	3.32	67	0.59	1.6	1.8	6
132S	6	2.6	6.85	79	0.71	1.8	1.8	7
	8	1.2	4.05	73	0.60	1.6	1.8	6
132M1	6	3.3	7.96	80	0.76	1.8	1.8	7
	8	1.6	5.26	76	0.60	1.6	1.8	6
132M2	6	4.5	10.95	82	0.75	1.8	1.8	7
	8	2.2	7.02	77	0.60	1.6	1.8	6
160M	6	6.5	14.84	84	0.76	1.8	1.8	7
	8	3.2	9.43	80	0.61	1.6	1.8	6
160L	6	9.0	20.21	86	0.77	1.8	1.8	7
	8	4.5	12.97	82	0.62	1.6	1.8	6
180L	6	13	29.07	86	0.77	1.5	1.8	7
	8	6.5	17.77	81	0.65	1.5	1.8	6
200L1	6	17	35.5	87	0.80	1.5	1.8	7
	8	8.5	20.6	82	0.66	1.5	1.8	6
200L2	6	21	44.3	88	0.80	1.5	1.8	7
	8	11	27.8	83	0.68	1.5	1.8	6
225M	6	30	62.3	89	0.83	1.5	1.8	7
	8	15	32.2	87	0.78	1.5	1.8	6
250M	6	37	72.1	90	0.86	1.5	1.8	7
	8	18	38.5	87	0.80	1.5	1.8	6
280S	6	45	86.8	90	0.86	1.5	1.8	7
	8	21	46.2	88	0.81	1.5	1.8	6
280M1	6	55	104.7	91	0.82	1.5	1.8	7
	8	28	57.2	89	0.81	1.5	1.8	6
280M2	6	65	122	91	0.82	1.5	1.8	7
	8	32	66.6	89	0.81	1.5	1.8	6
315S	6	75	145.1	91	0.84	1.5	1.8	7
	8	37	40.4	90	0.78	1.5	1.8	6
315M	6	90	171.6	92	0.85	1.5	1.8	7
	8	45	90.4	91	0.80	1.5	1.8	6

TECHNICAL DATA OF Y3DT SERIES

Frame reference and size		Rated power	Full load current at rated voltage	Efficiency	Power factor	Direct on line starting torque ratio	Direct on line pull out torque ratio	Direct on line starting current ratio
Type	Poles	Output (kw)	Amps (A)	η (%)	Power factor (cos Φ)	LRT/RLT	BDT/RLT	LRA/RLA
315L1	6	110	209.5	92	0.85	1.5	1.8	7
	8	55	115.7	91	0.78	1.5	1.8	6
315L2	6	132	252.0	92	0.85	1.5	1.8	7
	8	66	137.4	91	0.78	1.5	1.8	6
112M	4	2.3	5.88	79	0.73	2	1.8	7.5
	6	0.8	3.16	65	0.57	1.4	1.8	6.5
132S	4	3.1	4.14	81	0.79	2	1.8	7.5
	6	1.1	3.9	71	0.60	1.4	1.8	6.5
132M	4	4.5	9.76	83	0.82	2	1.8	7.5
	6	1.5	4.66	74	0.65	1.4	1.8	6.5
160M	4	7.5	15.98	84	0.82	1.8	1.8	7.5
	6	2.6	7.33	79	0.67	1.4	1.8	6.5
160L	4	10.2	20.64	86	0.85	1.8	1.8	7.5
	6	3.5	9.46	81	0.68	1.4	1.8	6.5
180M	4	13	24.22	86	0.90	1.8	1.8	8
	6	4.5	7.72	80	0.80	1.4	1.8	7.5
180L	4	16	29.63	87	0.90	1.8	1.8	8
	6	6	13.56	81	0.81	1.4	1.8	7.5
200L	4	22	40.56	87	0.90	1.8	1.8	8
	6	8	17.75	82	0.82	1.4	1.8	7.5
225S	4	28	53.32	89	0.88	1.8	1.8	8
	6	10	21.10	83	0.85	1.4	1.8	7.5
225M	4	34	63.11	89	0.89	1.8	1.8	8
	6	12	24.71	83	0.86	1.4	1.8	7.5
250M	4	44	78.09	90	0.92	1.8	1.8	8
	6	15.5	32.12	85	0.85	1.4	1.8	7.5
280S	4	55	98.47	90	0.92	1.8	1.8	8
	6	18	37	85	0.85	1.4	1.8	7.5
280M	4	66	116.88	91	0.92	1.8	1.8	8
	6	21	42.54	86	0.86	1.4	1.8	7.5
315S	4	75	136.34	90	0.91	1.8	1.8	8
	6	27	55.27	87	0.84	1.4	1.8	7.5
	8	19	43.8	89	0.73	1.3	1.8	5.5

				
RAL 6002	RAL 6011	RAL 6004	RAL 6012	RAL 6026
				
RAL 6028	RAL 6032	RAL 6034	RAL 7000	RAL 7010
				
RAL 7030	RAL 7036	RAL 7035	RAL 8001	RAL 8012
				
RAL 8017	RAL 8022	RAL 9006	RAL 9007	RAL 9005
				
RAL 9017	RAL 1001	RAL 1003	RAL 1011	RAL 1035
				
RAL 1034	RAL 2007	RAL 2010	RAL 2012	RAL 2003
				
RAL 2000	RAL 3001	RAL 3007	RAL 3017	RAL 3026
				
RAL 4011	RAL 4012	RAL 4003	RAL 4009	RAL 4001
				
RAL 5018	RAL 5007	RAL 5010	RAL 5017	RAL 5009
				
RAL 5015	RAL 5014	RAL 5004	RAL 5021	RAL 5019



A series of horizontal lines for writing, starting with a solid line followed by a dashed blue line, and then several solid lines.



A series of horizontal lines for writing, starting with a solid line followed by a dashed blue line, and then several solid lines.